

Hydrostatic Speed Variator



 **TB Wood's**[®]
Altra Industrial Motion



DISTRIBUIDOR MEX (55) 53 63 23 31 MTY (81) 83 54 10 18
AUTORIZADO QRO (442) 1 95 72 60 ventas@industrialmagza.com

TB Wood's

TB Wood's is an industry leading designer and manufacturer of mechanical power transmission equipment for industrial control. Our mechanical product lines include: clutch and brake, synchronous and belted variable speed drives; grid, disc, jaw, gear coupling and elastomeric coupling products; sheaves and bushings. Registered trademarks include Sure-Flex Plus®, Dura-Flex®, G-Flex®, and Sure-Grip®.

TB Wood's was founded in 1857 and began as a foundry producing wood burning stoves. Our company's tradition of product innovation started early. TB Wood's entered the power transmission industry at the turn of the century with the introduction of flat belted drives and line shafting.

VISIT US ON THE WEB AT
TBWOODS.COM



Altra Industrial Motion

Altra is a leading global designer and manufacturer of quality power transmission and motion control products utilized on a wide variety of industrial drivetrain applications. Altra clutches and brakes, couplings, gearing and PT component product lines are marketed under the industries most well known manufacturing brands. Each brand is committed to the guiding principles of operational excellence, continuous improvement and customer satisfaction. Highly-engineered Altra solutions are sold in over 70 countries and utilized in a variety of major industrial markets, including food processing, material handling, packaging machinery, mining, energy, automotive, primary metals, turf and garden and many others.

Altra's leading brands include **Ameridrives**, **Bauer** Gear Motor, **Bibby** Turboflex, **Boston** Gear, **Delroyd** Worm Gear, **Formsprag** Clutch, **Guardian** Couplings, **Huco**, **Industrial** Clutch, **Inertia** Dynamics, **Kilian**, **Lamiflex** Couplings, **Marland** Clutch, **Matrix**, **Nuttall** Gear, **Stieber**, **Stromag**, **Svendborg** Brakes, **TB Wood's**, **Twiflex**, **Warner** Electric, **Warner** Linear and **Wichita** Clutch.

VISIT US ON THE WEB AT **ALTRAMOTION.COM**



HSV and HSV-A



HSV

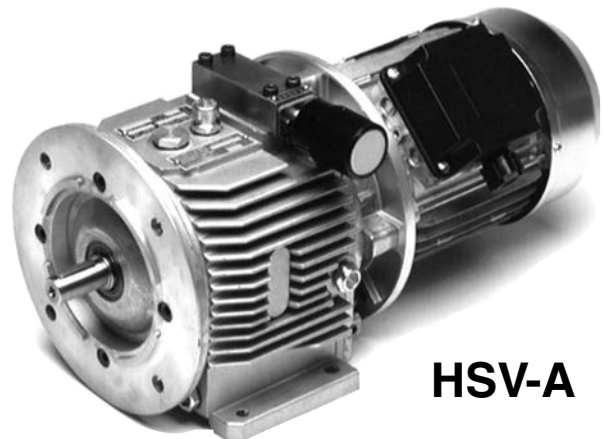

HSV-A

Principle of Operation

The Hydrostatic Speed Variator is an integrated hydrostatic transmission consisting of a variable displacement radial piston pump driving a fixed displacement radial piston motor. The pump-motor system is completely self-contained within one case providing light weight and ease of maintenance and serviceability.

The hydrostatic closed loop operates in the following manner. The input shaft (6) rotates the cylinder block of the radial piston pump (1). The pistons (13) stroke in and out of their cylinders pumping hydraulic oil through the distributor shaft (9) to the radial piston hydraulic motor (2). The oil then returns directly to the pump. In both the pump and the motor the stroke of the pistons is limited by the eccentric rings (7). The position of the pump eccentric ring is controlled by the regulating pin (8). This varies the flow rate from the pump to the motor. Since the motor eccentric ring is fixed in place, the speed of the hydraulic motor is directly proportional to the flow received from the pump. The pump eccentric ring can be moved to either side of the concentric center position thereby reversing the flow and reversing the output shaft. When a torque load is applied to the output shaft, a pressure which is proportional to the torque, is produced in the passages which transmit oil from the pump to the hydraulic motor. Some leakage occurs in these high pressure sections causing slip. The low pressure return line is supplied by a small charge pump (3). It makes up for the small leakage and maintains a positive pressure (approximately 120 psi) at the inlet of the main pump. The charge pump also provides positive lubrication and power to the hydraulic controls. The crossover check valves (5) direct the charge flow to the low pressure side of the closed loop. High system pressure is limited by the main relief valves (11). These provide protection from excessive torque overloads for both the variator and the driven machine.

The input and output shafts are independently mounted in their end covers and coupled to their respective cylinder blocks. Consequently, no shaft deflections are transmitted to the hydraulic mechanism and no hydraulic forces are carried by the shaft bearings.

The simplicity of concept and design make the HSV unique among variable speed drives.

Hydraulic Schematic

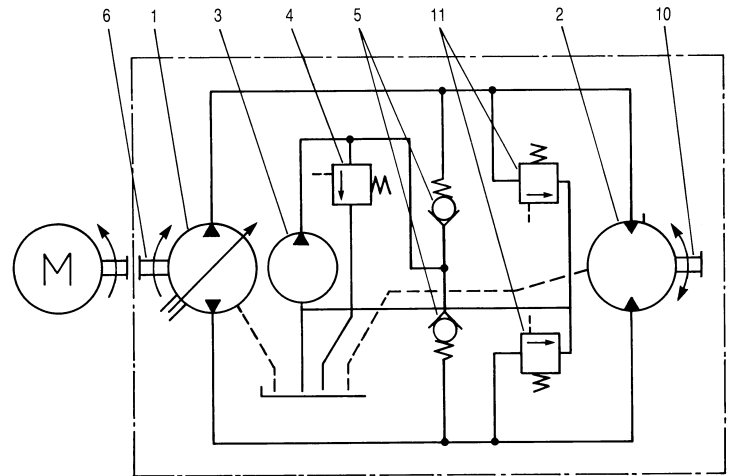

Legend

- | | |
|------------------------|--------------------------|
| 1. Radial Piston Pump | 8. Regulating Pin |
| 2. Radial Piston Motor | 9. Distributor Shaft |
| 3. Charge Pump | 10. Output Shaft |
| 4. Charge Relief Valve | 11. Safety Relief Valves |
| 5. Check Valves | 12. Case |
| 6. Input Shaft | 13. Pistons |
| 7. Eccentric Ring | |

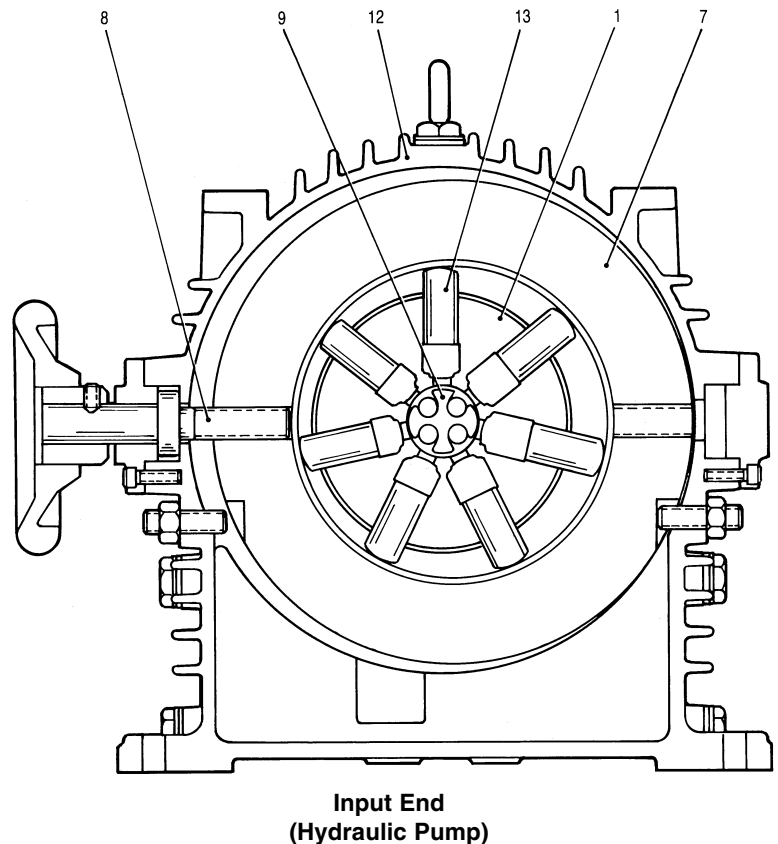

Hydrostatic Speed Variator

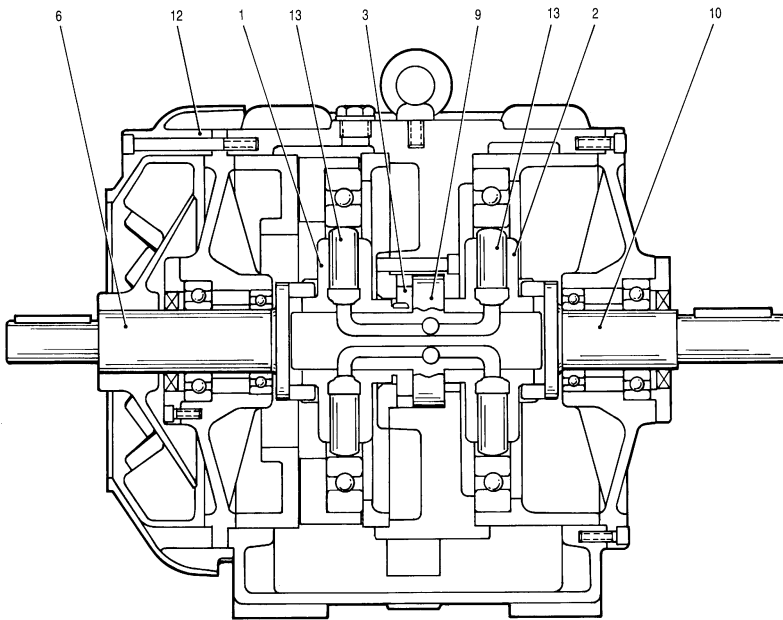
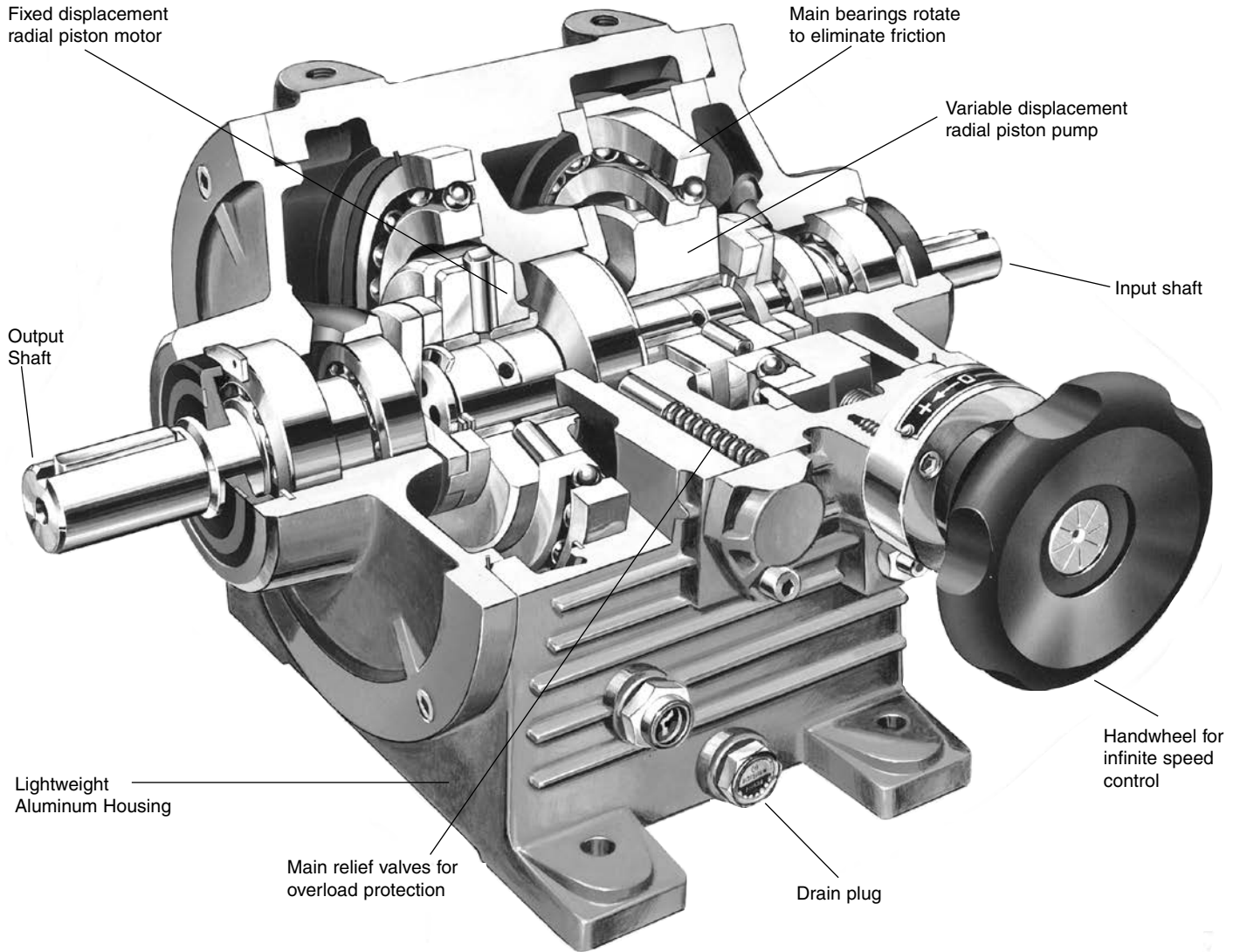

Size 15

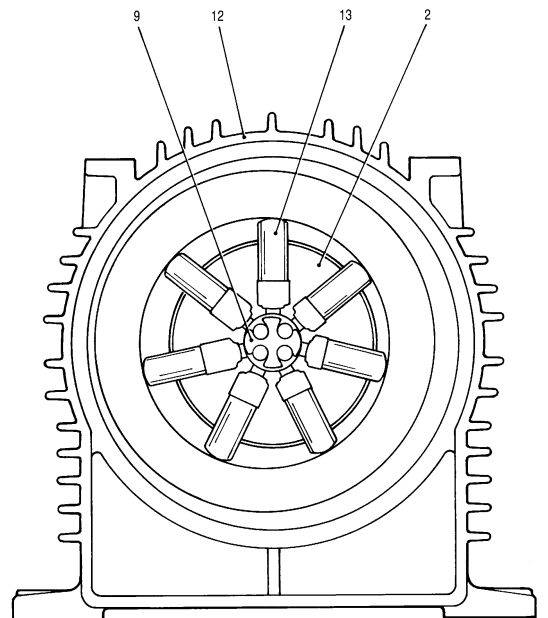

Output End (Hydraulic Motor)

Applications



Winding

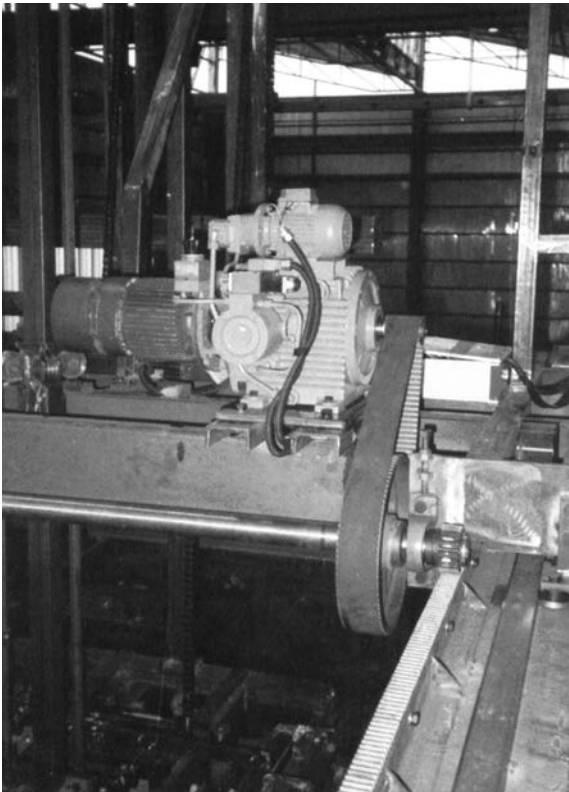

Materials Handling

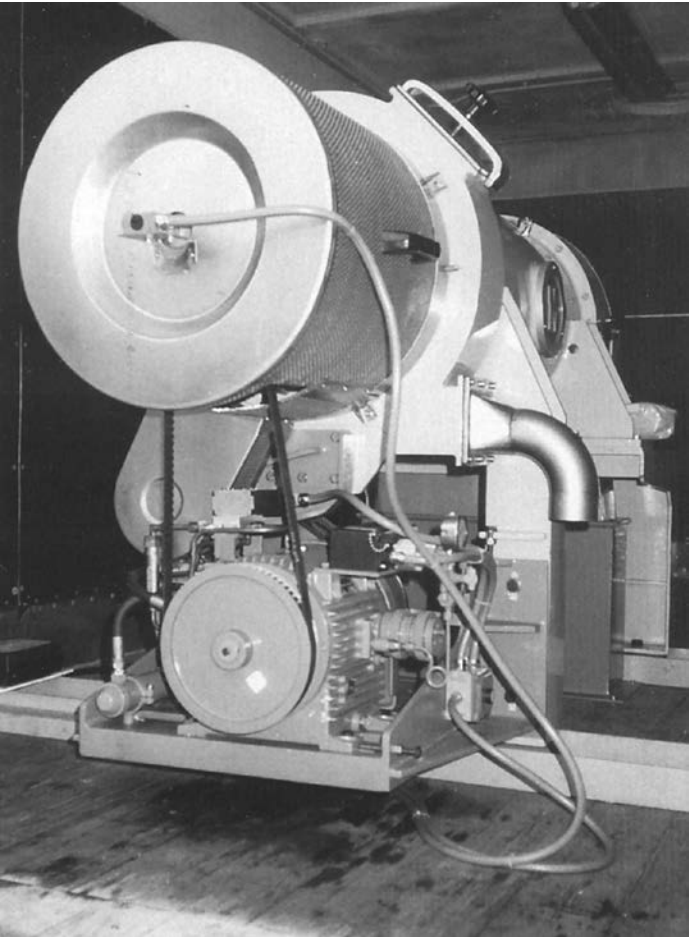

Centrifuge

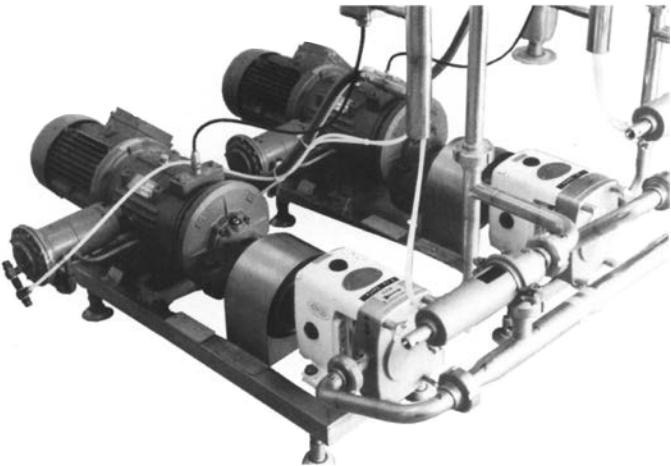

Pumping

HSV Versus HSV-A Overview



HSV

Feature Comparison

Output HP Range
Relative Cost
Housing Material
Internal Gearing

HSV

1/2 to 20
Higher
Cast Iron
Not Available

HSV-A

1/3 to 4
Lower
Aluminum
Optional

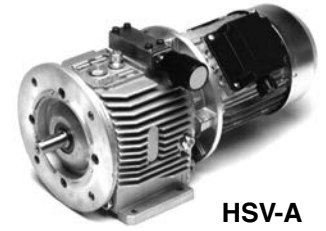

HSV-A

Input Options

Shaft (T 10)
NEMA C
Top Mount Motor

HSV

Std
Opt
Opt

HSV-A

Opt
Std
NA

Output Options

Shaft (T 10)
NEMA C

HSV

Std
Opt

HSV-A

Opt
Std

Manual Controls

00 - Handwheel
01 - Right Angle HW
02 - Lever
03 - HD Lever
09 - Flexible Shaft
12 - Clevis

HSV

Std
Opt
Opt
Opt
Opt
Opt

HSV-A

Std
Opt
Opt
NA
NA
NA

Remote Controls

20 - Electric (Fast)
22 - Electric (Slow)
23 - Electric (Very Slow)
31 - Hydraulic for PLC
37 - Electro-Hydraulic
38 - Electro-Hydraulic
46 - HW w/ ramp start
49 - Electric w/ ramp start
52 - Hydraulic-Pneumatic
53 - Hydraulic-Pneumatic
65 - Elect-Hydra w/ ps & 0
66 - Elect-Hydra w/ presets
67 - Electro-Hydraulic
68 - Electro-Hydraulic
71 - Synchronized
00/3 - Auto Winder

HSV

Opt
Opt
Opt
NA
Opt
Opt
Opt
Opt
Opt
Opt
Opt
Opt
Opt
Opt
Opt
NA
NA
NA

HSV-A

Opt
Opt
Opt
Opt
Opt
Opt
Opt
Opt
Opt
NA
Opt
Opt
Opt
Opt
NA
Opt
Opt

Accessories

0 - Dial Indicator HW
3 - Press Compensator
4 - Adj. Tor. Limit Valve
6 - Zero Dev. for Man Cont
8A - Tach PU w/ Analog M
8D - Tach PU w/ Digital M
8L - Tach PU w/o Meter
9(2) - L Switch Box for RC
9(3) - L Switch Box for RC
9(6) - L Switch Box for RC

HSV

Opt
Opt
Opt
Opt
Opt
Opt
Opt
Opt
Opt
Opt

HSV-A

Opt
NA
NA
NA
Opt
Opt
Opt
Opt
Opt
Opt

Options

A - Separate Charge Pump
B - Bypass Valve
C - Vertical Mount
D - Reversible Charge Pump
F - Flow Control
G - Potentiometer Feedback
M - Pressure Tap
M(G) - Press Tap w/ Gauge
M(PS) - Press Tap w/ Switch
N - High Temp, Cutoff
P - Oil Preheat Kit
Q - Compensated Oil Flow
R - External Cooler Valve
RR - Valve & Radiator
S - Electronic Adjuster (ERC)
W- Remote Speed Set
Z(I) - Press Act. Breather
Z(2) - Epoxy Paint
Z(3) - Synthetic Oil

HSV

Opt
Opt
Opt
Opt
Opt
Opt
Opt
Opt
Opt
Opt
Opt
Opt
Opt
Opt
Opt
Opt
Opt
Opt
Opt

HSV-A

NA
NA
Opt
Opt
NA
Opt
Opt
Opt
Opt
Opt
NA
Opt
Opt
Opt
Opt
Opt
Opt
Opt

Ratings

HSV 11

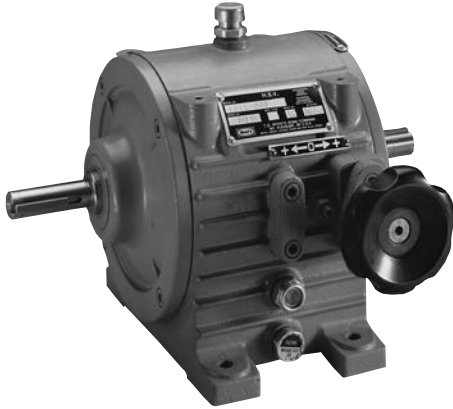

0.45 HP @ max. output speed with 1/2 HP electric motor

Max. Output Speed (RPM)	Running Torque (lb/ft)	Gearbox ratio/model	Weight (lbs)	
			w/motor	w/o motor
1700	1.4	—	48	23
833	2.9	2.04 DC11*	85	60
732	3.3	2.32 DC11*	85	60
600	4.0	2.83 DC11*	85	60
535	4.5	3.18 DC11*	85	60
472	5.0	3.60 DC11*	85	60
437	5.5	3.89 DC02	92	67
353	6.8	4.82 DC02	92	67
306	7.8	5.56 DC02	92	67
247	9.7	6.89 DC02	92	67
218	11.0	7.80 DC02	92	67
208	11.5	8.19 DC02	92	67
183	13.0	9.28 DC02	92	67
171	14.0	9.95 DC02	92	67
151	16	11.27 DC02	92	67
133	18	12.82 DC02	92	67
107	22	15.95 DC02	92	67
82	29	20.59 DC02	92	67
70	34	24.39 DC02	92	67
66	36	25.92 DC12	96	71
54	44	31.19 DC12	96	71
44	54	38.31 DC12	96	71
36	67	47.87 DC12	96	71
27	91	64.80 DC23*	134	109
22	109	78.05 DC23*	134	109
20	124	88.46 DC23*	134	109

A2

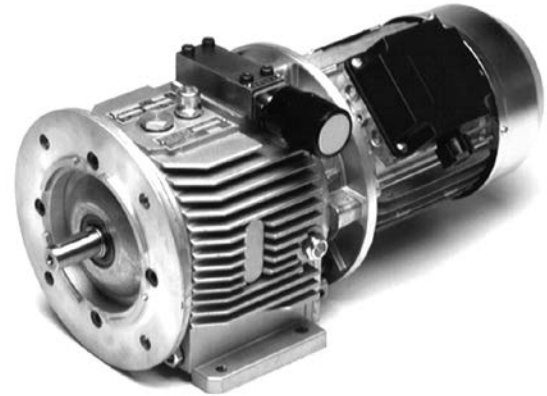

56C Input & Output Std.

.33 HP @ max output speed with 1/2 HP electric motor

Max. Speed (RPM)	Running Torque (ft. lbs.)	Gearbox ratio/model	Weight (lbs)	
			w/motor	w/o motor
1650	1.0	—	41	16
809	2.0	2.04 DC11*	78	53
711	2.3	2.32 DC11*	78	53
583	2.8	2.83 DC11*	78	53
519	3.2	3.18 DC11*	78	53
458	3.6	3.60 DC11*	78	53
424	3.9	3.89 DC02	85	60
342	4.8	4.82 DC02	85	60
297	5.6	5.56 DC02	85	60
239	6.9	6.89 DC02	85	60
212	7.8	7.80 DC02	85	60
201	8.2	8.19 DC02	85	60
178	9.3	9.28 DC02	85	60
166	10.0	9.95 DC02	85	60
146	11.3	11.27 DC02	85	60
129	12.8	12.82 DC02	85	60
103	16.0	15.95 DC02	85	60
80	20.6	20.59 DC02	85	60
68	24.4	24.39 DC02	85	60
64	25.9	25.92 DC12	89	64
53	31.2	31.19 DC12	89	64
43	38.3	38.31 DC12	89	64
34	47.9	47.87 DC12	89	64
25	64.8	64.80 DC23*	127	102
21	78.1	78.05 DC23*	127	102
19	88.5	88.46 DC23*	127	102

Other gearbox ratios available.

*NOTE: Denotes single, triple, or quadruple reduction which reverses the output shaft rotation. If single rotation control is used, check for proper installation.

HSV 12

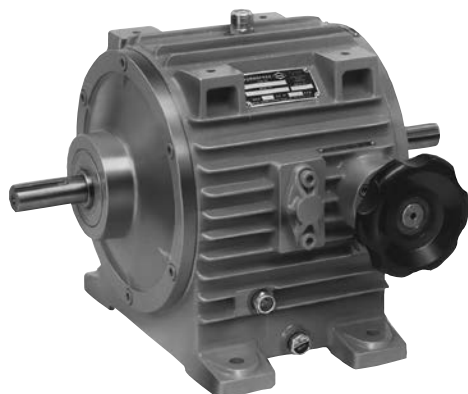

0.85 HP @ max. output speed with 1 HP electric motor

Max. Output Speed (RPM)	Running Torque (lb/ft)	Gearbox ratio/model	Weight (lbs)	
			w/motor	w/o motor
1700	2.6	—	65	29
834	5.4	2.04 DC11*	100	64
733	6.1	2.32 DC11*	100	64
601	7.4	2.83 DC11*	100	64
535	8.4	3.18 DC11*	100	64
473	9.5	3.60 DC11*	100	64
437	10.2	3.89 DC02	110	73
353	12.7	4.82 DC02	110	73
306	14.6	5.56 DC02	110	73
247	18.0	6.89 DC02	110	73
218	21	7.80 DC02	110	73
208	22	8.19 DC02	110	73
184	24	9.28 DC02	110	73
171	26	9.95 DC02	110	73
151	30	11.27 DC02	110	73
133	34	12.82 DC02	110	73
127	35	13.39 DC12	114	77
102	44	16.73 DC12	114	77
91	50	18.79 DC12	114	77
80	56	21.28 DC12	114	77
72	62	23.74 DC22	139	102
59	76	28.80 DC22	139	102
49	91	34.69 DC22	139	102
40	112	42.82 DC22	139	102
37	121	46.25 DC32	154	119
30	151	57.53 DC32	154	119
20	231	88.18 DC33*	167	132

A4

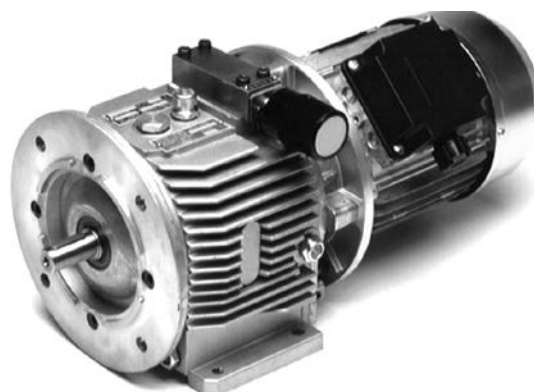

143TC Input & Output Std.
 .75 HP @ max output speed with 1 HP electric motor

Max. Speed (RPM)	Running Torque (ft. lbs.)	Gearbox ratio/model	Weight (lbs)	
			w/motor	w/o motor
1650	2.1	—	60	24
809	4.3	2.04 DC11*	95	59
711	4.9	2.32 DC11*	95	59
583	5.9	2.83 DC11*	95	59
519	6.7	3.18 DC11*	95	59
458	7.6	3.60 DC11*	95	59
424	8.2	3.89 DC02	105	68
342	10.1	4.82 DC02	105	68
297	11.7	5.56 DC02	105	68
239	14.5	6.89 DC02	105	68
212	16.4	7.80 DC02	105	68
201	17.2	8.19 DC02	105	68
178	19.5	9.28 DC02	105	68
166	20.9	9.95 DC02	105	68
146	23.7	11.27 DC02	105	68
129	26.9	12.82 DC02	105	68
123	28.1	13.39 DC12	109	72
99	35.1	16.73 DC12	109	72
88	39.5	18.79 DC12	109	72
78	44.7	21.28 DC12	109	72
70	49.9	23.74 DC22	134	97
57	60.5	28.80 DC22	134	97
48	72.8	34.69 DC22	134	97
39	89.9	42.82 DC22	134	97
36	97.1	46.25 DC32	149	114
29	120.8	57.53 DC32	149	114
19	185.2	88.18 DC33*	162	127

Other gearbox ratios available.

*NOTE: Denotes single, triple, or quadruple reduction which reverses the output shaft rotation. If single rotation control is used, check for proper installation.

Ratings

HSV 13



1.7 HP @ max. output speed with 2 HP electric motor

Max. Output Speed (RPM)	Running Torque (lb/ft)	Gearbox ratio/model	Weight (lbs)	
			w/motor	w/o motor
1700	5	—	105	60
834	11	2.04 DC11*	140	95
733	12	2.32 DC11*	140	95
600	15	2.83 DC11*	140	95
535	17	3.18 DC11*	140	95
473	19	3.60 DC11*	140	95
437	20	3.89 DC02	149	104
353	25	4.82 DC02	149	104
265	34	6.40 DC21*	151	106
260	35	6.53 DC12	153	108
216	41	7.85 DC12	153	108
176	51	9.65 DC12	153	108
158	56	10.70 DC12	153	108
126	70	13.39 DC12	153	108
115	77	14.69 DC22	178	133
101	88	16.75 DC22	178	133
71	125	23.74 DC22	178	133
68	130	24.73 DC22	178	133
59	151	28.8 DC22	178	133
54	164	31.16 DC32	195	150
51	174	33.05 DC32	195	150
45	195	37.23 DC32	195	150
36	243	46.25 DC32	195	150
29	302	57.53 DC32	195	150
24	368	70.12 DC43*	257	212
21	420	79.96 DC43*	257	212

A8

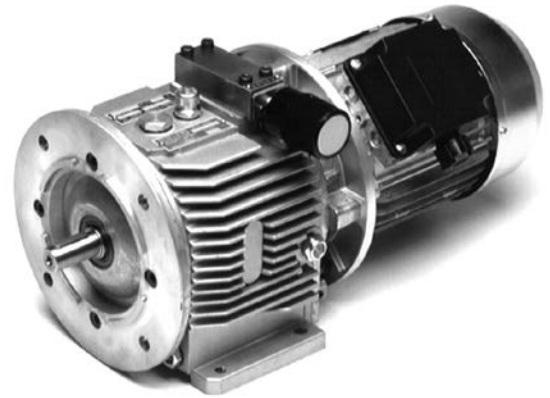

145TC Input & Output Std.
1.5 HP @ max output speed with 2 HP electric motor

Max. Speed (RPM)	Running Torque (ft. lbs.)	Gearbox ratio/model	Weight (lbs)	
			w/motor	w/o motor
1650	4.2	—	90	45
809	8.6	2.04 DC11*	125	80
711	9.7	2.32 DC11*	125	80
583	11.9	2.83 DC11*	125	80
519	13.4	3.18 DC11*	125	80
458	15.1	3.60 DC11*	125	80
424	16.3	3.89 DC02	134	89
342	20.2	4.82 DC02	134	89
258	26.9	6.40 DC21*	136	91
253	27.4	6.53 DC12	138	93
208	33.4	7.85 DC12	138	93
171	40.5	9.65 DC12	138	93
154	44.9	10.70 DC12	138	93
123	56.2	13.39 DC12	138	93
112	61.7	14.69 DC22	163	118
99	70.4	16.75 DC22	163	118
70	99.7	23.74 DC22	163	118
67	103.9	24.73 DC22	163	118
57	121.0	28.8 DC22	163	118
53	130.9	31.16 DC32	180	135
50	138.8	33.05 DC32	180	135
44	156.4	37.23 DC32	180	135
36	194.3	46.25 DC32	180	135
29	241.6	57.53 DC32	180	135
24	294.5	70.12 DC43*	242	197
21	335.8	79.96 DC43*	242	197

Other gearbox ratios available.

*NOTE: Denotes single, triple, or quadruple reduction which reverses the output shaft rotation. If single rotation control is used, check for proper installation.

HSV 14

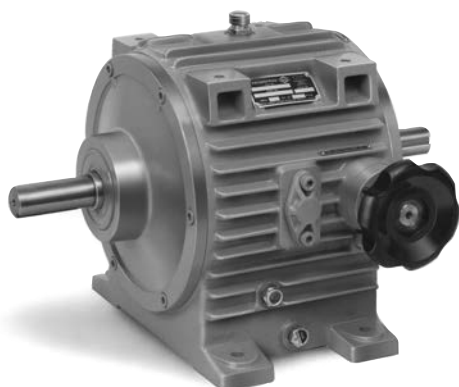

2.5 HP @ max. output speed with 3 HP electric motor

Max. Output Speed (RPM)	Running Torque (lb/ft)	Gearbox ratio/model	Weight (lbs)	
			w/motor	w/o motor
1700	8	—	134	71
817	16	2.08 DC21*	187	122
702	20	2.42 DC21*	187	122
550	26	3.09 DC21*	187	122
463	28	3.67 DC21*	187	122
328	40	5.18 DC22	213	148
293	45	5.79 DC22	213	148
261	50	6.51 DC22	213	148
224	58	7.57 DC22	213	148
200	65	8.48 DC22	213	148
156	84	10.89 DC22	213	148
139	94	12.20 DC22	213	148
115	113	14.69 DC22	213	148
82	160	20.70 DC32	231	166
64	205	26.57 DC32	231	166
54	241	31.16 DC32	231	166
48	282	35.25 DC42	279	214
29	450	58.27 DC53*	292	227
21	615	79.69 DC53*	325	260

A10

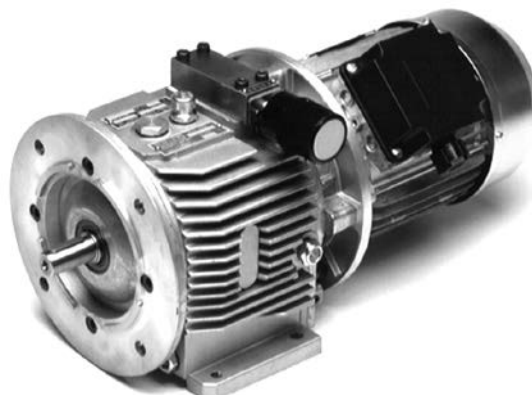

182TC Input & Output Std.
2.0 HP @ max output speed with 3 HP electric motor

Max. Speed (RPM)	Running Torque (ft. lbs.)	Gearbox ratio/model	Weight (lbs)	
			w/motor	w/o motor
1650	6.0	—	139	76
793	12.5	2.08 DC21*	192	127
682	14.5	2.42 DC21*	192	127
534	18.5	3.09 DC21*	192	127
450	22.0	3.67 DC21*	192	127
319	31.1	5.18 DC22	218	153
285	34.7	5.79 DC22	218	153
253	39.1	6.51 DC22	218	153
218	45.4	7.57 DC22	218	153
195	50.9	8.48 DC22	218	153
152	65.3	10.89 DC22	218	153
135	73.2	12.2 DC22	218	153
112	88.1	14.69 DC22	218	153
80	124.2	20.70 DC32	236	171
62	159.4	26.57 DC32	236	171
53	187.0	31.16 DC32	236	171
47	211.5	35.25 DC42	284	219
28	349.6	58.27 DC53*	297	232
22	460.1	79.69 DC53*	330	265

Other gearbox ratios available.

*NOTE: Denotes single, triple, or quadruple reduction which reverses the output shaft rotation. If single rotation control is used, check for proper installation.

Ratings

HSV 15

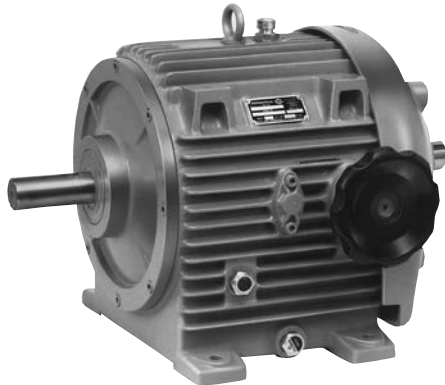

4 HP @ max. output speed with 5 HP electric motor

Max. Output Speed (RPM)	Running Torque (lb/ft)	Gearbox ratio/model	Weight (lbs)	
			w/motor	w/o motor
1700	12	—	215	132
817	26	2.08 DC21*	266	183
702	30	2.42 DC21*	266	183
627	33	2.71 DC21*	266	183
513	41	3.31 DC31*	281	198
463	45	3.67 DC31*	281	198
427	49	3.97 DC22	292	209
367	57	4.63 DC22	292	209
328	64	5.18 DC22	292	209
293	72	5.79 DC22	292	209
261	80	6.51 DC22	292	209
224	94	7.57 DC22	292	209
215	98	7.90 DC32	323	240
173	121	9.80 DC32	323	240
145	145	11.71 DC32	323	240
116	180	14.55 DC32	323	240
113	186	15.03 DC32	323	240
101	206	16.67 DC32	323	240
91	231	18.67 DC32	323	240
80	260	21.06 DC42	358	275
69	302	24.41 DC42	358	275
69	320	25.88 DC42	358	275
58	362	29.29 DC42	358	275
52	396	32.09 DC52	389	306
44	475	38.45 DC52	389	306
27	780	62.87 DC63*	514	431
22	950	77.46 DC63*	514	431

A12

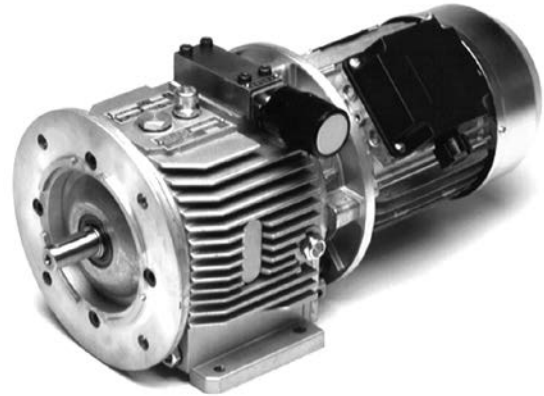

184TC Input & Output Std.

3.75 HP @ max output speed with 5 HP electric motor

Max. Speed (RPM)	Running Torque (ft. lbs.)	Gearbox ratio/model	Weight (lbs)	
			w/motor	w/o motor
1650	11.5	—	159	76
793	23.9	2.08 DC21*	210	127
682	27.8	2.42 DC21*	210	127
609	31.2	2.71 DC21*	210	127
498	38.1	3.31 DC31*	225	142
450	42.2	3.67 DC31*	225	142
416	45.7	3.97 DC22	236	153
356	53.2	4.63 DC22	236	153
319	59.6	5.18 DC22	236	153
285	66.6	5.79 DC22	236	153
253	74.9	6.51 DC22	236	153
218	87.1	7.57 DC22	236	153
209	90.9	7.90 DC32	267	184
168	112.7	9.80 DC32	267	184
141	134.7	11.71 DC32	267	184
113	167.3	14.55 DC32	267	184
110	172.8	15.03 DC32	267	184
99	191.7	16.67 DC32	267	184
88	214.7	18.67 DC32	267	184
78	242.2	21.06 DC42	302	219
68	280.7	24.41 DC42	302	219
64	297.6	25.88 DC42	302	219
56	336.8	29.29 DC42	302	219
51	369.0	32.09 DC52	333	250
43	442.2	38.45 DC52	333	250
26	723.0	62.87 DC63*	458	375
21	890.8	77.46 DC63*	458	375

Other gearbox ratios available.

*NOTE: Denotes single, triple, or quadruple reduction which reverses the output shaft rotation. If single rotation control is used, check for proper installation.

HSV 16

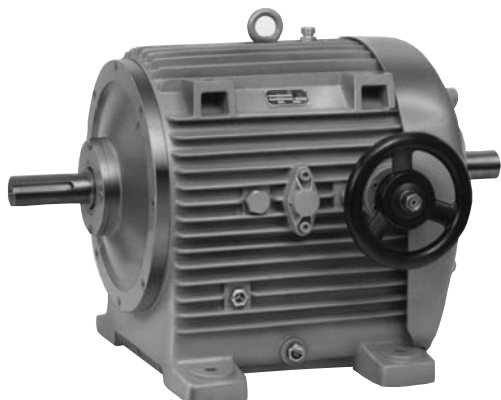

7.6 HP @ max. output speed with 10 HP electric motor

Max. Output Speed (RPM)	Running Torque (lb/ft)	Gearbox ratio/model	Weight (lbs)	
			w/motor	w/o motor
1700	23	—	431	286
817	48	2.08 DC31*	510	365
659	59	2.58 DC31*	510	365
552	71	3.08 DC41*	561	416
384	102	4.43 DC32	539	394
309	127	5.50 DC32	539	394
252	155	6.74 DC32	539	394
215	182	7.90 DC32	539	394
173	225	9.80 DC32	539	394
138	282	12.28 DC42	605	460
112	348	15.12 DC42	605	460
99	394	17.15 DC52	636	491
73	535	23.27 DC52	636	491
46	852	37.05 DC62	785	640
35	1121	48.73 DC62	785	640
34	1167	50.73 DC63	761	616
32	1238	53.82 DC63	761	616
27	1446	62.87 DC63	761	616
23	1722	74.87 DC73*	884	739

HSV 16B

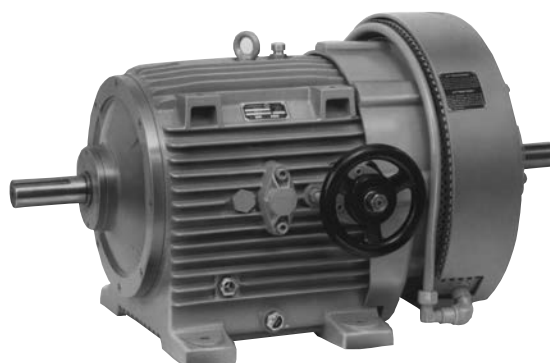

12 HP @ max output speed with 15 HP electric motor

Max. Speed (RPM)	Running Torque (ft. lbs.)	Gearbox ratio/model	Weight (lbs)	
			w/motor	w/o motor
1500	44	—	612	330
721	92	2.08 DC31*	691	409
581	114	2.58 DC31*	691	409
487	136	3.08 DC41*	704	422
453	146	3.31 DC51*	759	477
371	178	4.04 DC51*	759	477
327	202	4.58 DC42	786	504
280	235	5.35 DC42	786	504
242	272	6.19 DC42	786	504
206	320	7.28 DC42	786	504
176	374	8.50 DC42	786	504
147	449	10.2 DC42	786	504
123	532	12.10 DC52	817	535
107	616	14.00 DC52	817	535
87	755	17.15 DC52	817	535
82	800	18.14 DC62	966	684
40	1630	37.05 DC62	966	684
34	1900	43.11 DC72	1089	807
28	2300	52.24 DC73*	1065	783
25	2660	60.46 DC73*	1065	783
24	2720	61.89 DC83*	1281	999
21	3090	70.24 DC83*	1281	999

Other gearbox ratios available.

*NOTE: Denotes single, triple, or quadruple reduction which reverses the output shaft rotation. If single rotation control is used, check for proper installation.

Ratings

HSV 17

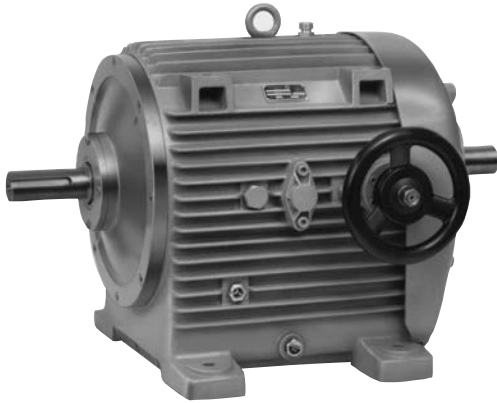

15 HP @ max. output speed with 20 HP electric motor

Max. Output Speed (RPM)	Running Torque (lb/ft)	Gearbox ratio/model	Weight (lbs)	
			w/motor	w/o motor
1400	53	—	790	484
307	239	4.56 DC62	1182	876
264	278	5.29 DC62	1182	876
220	333	6.35 DC62	1182	876
185	397	7.57 DC62	1182	876
159	461	8.78 DC62	1182	876
132	554	10.55 DC62	1182	876
120	608	11.59 DC62	1182	876
100	730	13.92 DC62	1182	876
88	830	15.80 DC62	1182	876
77	950	18.14 DC62	1182	876
64	1140	21.64 DC72	1306	1000
48	1500	28.63 DC72	1306	1000
34	2120	40.45 DC82	1531	1225
28	2560	48.82 DC82	1531	1225
25	2910	55.51 DC83*	1496	1190
22	3250	61.89 DC83*	1496	1190
20	3690	70.24 DC83*	1496	1190

HSV 17B



21HP @ max output speed with 30 HP electric motor

Max. Speed (RPM)	Running Torque (ft. lbs.)	Gearbox ratio/model	Weight (lbs)	
			w/motor	w/o motor
1400	75	—	1002	540
307	340	4.56 DC62	1394	932
264	400	5.29 DC62	1394	932
220	480	6.35 DC62	1394	932
185	570	7.57 DC62	1394	932
159	660	8.78 DC62	1394	932
132	790	10.55 DC62	1394	932
120	870	11.59 DC62	1394	932
100	1040	13.92 DC62	1394	932
88	1190	15.80 DC62	1394	932
77	1360	18.14 DC62	1394	932
64	1620	21.64 DC72	1517	1055
48	2150	28.63 DC72	1517	1055
42	2490	33.24 DC73	1493	1031
35	2930	39.08 DC83*	1708	1246
31	3330	44.38 DC83*	1708	1246
26	4040	53.80 DC93*	2007	1545
22	4620	61.63 DC93*	2007	1545
19	5440	72.47 DC93*	2007	1545

Other gearbox ratios available.

*NOTE: Denotes single, triple, or quadruple reduction which reverses the output shaft rotation. If single rotation control is used, check for proper installation.

HSV Performance Data

Performance Factors

- Intermittent torque is the torque to which the HSV can be loaded without overloading the electric motor. Momentary torque overloads up to the starting torque can be tolerated by the HSV.
- Continuous torque is the torque not to be exceeded under continuous operation.
- Minimum output speed at continuous torque is 50 RPM for all sizes. This results in the speed ratios as shown in the table below. It is possible to run somewhat below 50 RPM at reduced torque load.

Speed Ratios

RPM Input	Speed Ratio Available
1750	42:1
1450	36:1
1140	27:1

- Minimum input speed is 500 RPM to ensure sufficient charge flow. Lower input speeds can be accommodated by utilizing a separate charge pump, Option Code A.

Service Factors

The following Service Factors should be applied when selecting the HSV size.

Duty C₁

Running Hours Per Day	Service Factor C ₁
8	1
8-15	1.1
15-24	1.2

Cycling Loading C₂

Cycle Rate	Service Factor C ₂
Low	0
Medium (60 per hr)	0.1
High (10 per minute)	0.3
Very High (30 per minute)	Consult Factory

Temperature C₃

Ambient Temperature	Service Factor C ₃
Up to 80° F	0
From 85° F to 105° F	0.4
Higher than 105° F	Consult Factory

Service Factor is the sum of C₁, C₂, and C₃

$$S.F. = C_1 + C_2 + C_3$$

Power and Torque Performance at Output Shaft

HSV 11 With 1/2 HP Motor Starting Torque 5 ft. lbs.

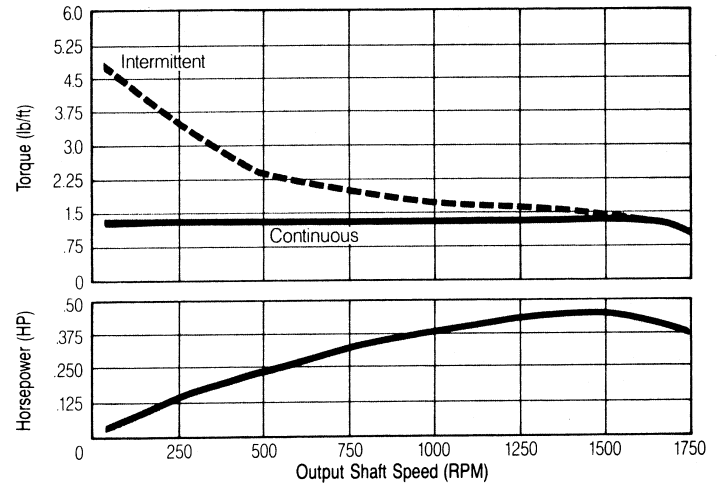

HSV 12 With 1 HP Motor Starting Torque 10 ft. lbs.

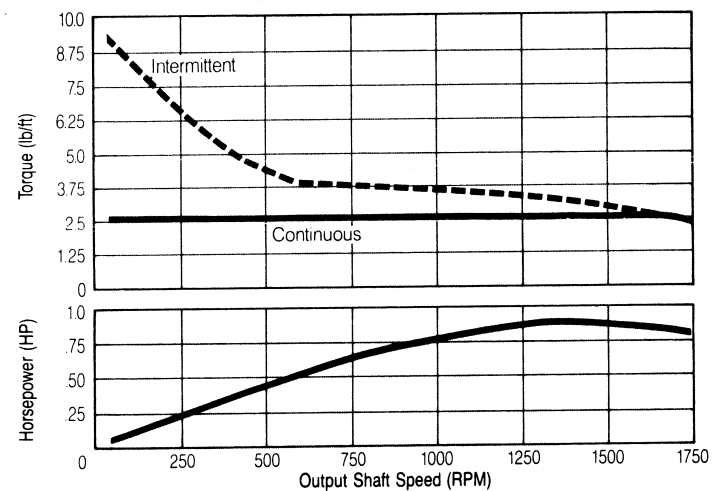

HSV 13 With 2 HP Motor Starting Torque 18 ft. lbs.

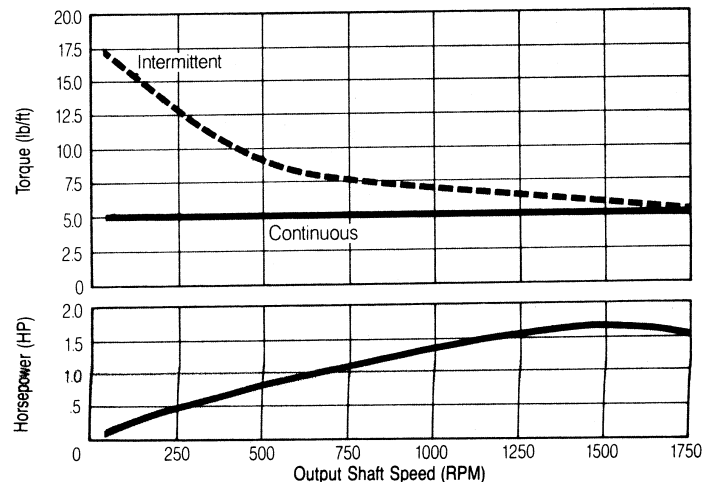

HSV Performance Data

HSV 14 With 3 HP Motor Starting Torque 25 ft. lbs.

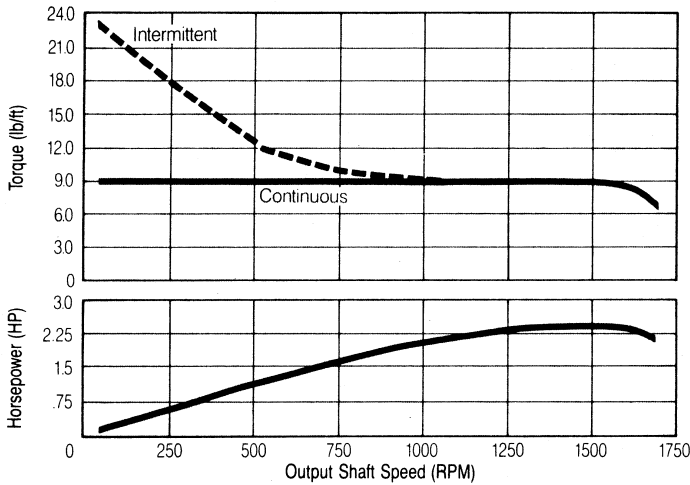

HSV 16B With 15 HP Motor Starting Torque 75 ft. lbs.

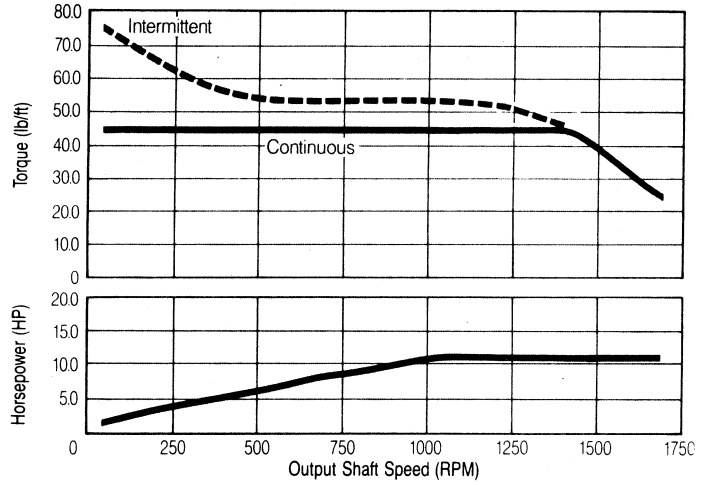

HSV 15 With 5 HP Motor Starting Torque 40 ft. lbs.

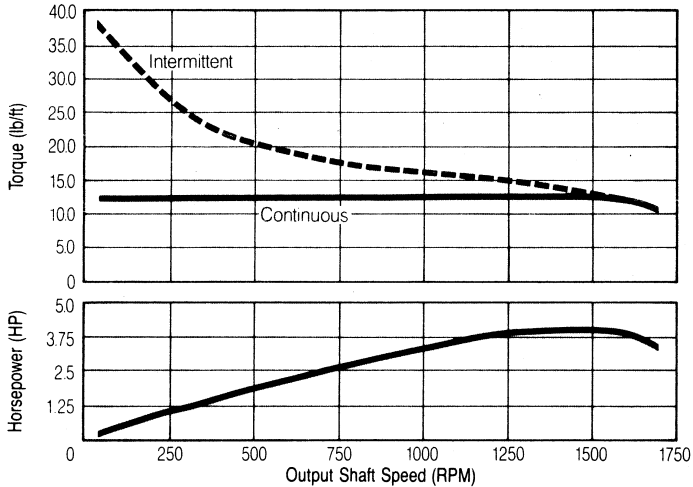

HSV 17 With 20 HP Motor Starting Torque 130 ft. lbs.

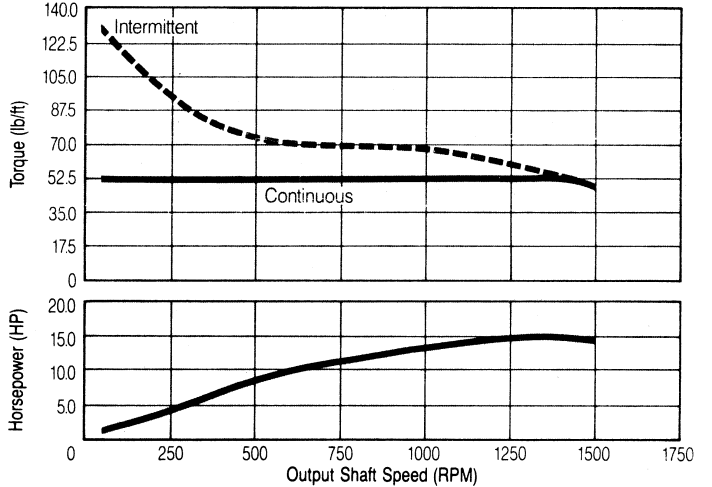

HSV 16 With 10 HP Motor Starting Torque 65 ft. lbs.

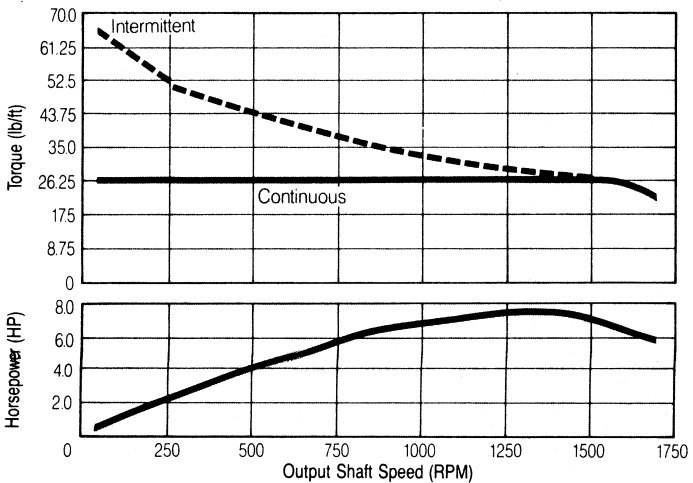

HSV 17B With 30 HP Motor Starting Torque 180 ft. lbs.

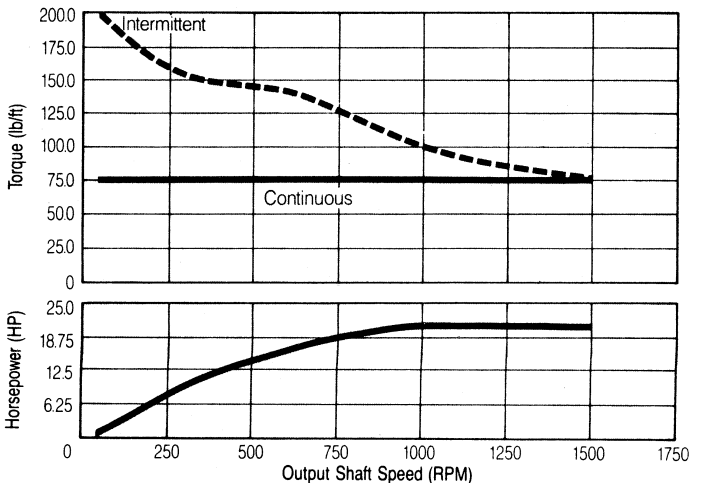

HSV-A Performance Data

Standard HSV-A UNIT

INPUT		Model	OUTPUT				
HP	RPM		RPM Range	Stable RPM	HP@ Max.	Running TQ (ft. lb.)	Start TQ (ft. lb.)
1/2	1750	A2	1750-0	50	0.35	1.0	4.8
1/3	1140	A2	1140-0	40	0.25	1.2	4.8
1	1750	A4	1750-0	50	0.72	2.2	9.2
3/4	1140	A4	1140-0	40	0.56	2.6	9.2
2	1750	A8	1750-0	50	1.44	4.3	17.0
1 1/2	1140	A8	1140-0	40	1.12	5.1	17.0
3	1750	A10	1750-0	50	2.06	6.0	36.9
2	1140	A10	1140-0	40	1.30	5.8	36.9
5	1750	A12	1750-0	50	3.44	10.3	36.9
3	1140	A12	1140-0	40	2.10	9.1	36.9

HSV-A/X UNIT (Internal Gear Reduction)

INPUT		Model	OUTPUT				
HP	RPM		RPM Range	Stable RPM	HP@ Max.	Running TQ (ft.lb.)	Start TQ (ft.lb.)
1/2	1750	A2/X	1120-0	50	0.35	1.6	4.8
1/3	1140	A2/X	730-0	40	0.25	1.8	4.8
1	1750	A4/X	1175-0	50	0.72	3.2	9.4
3/4	1140	A4/X	765-0	40	0.56	3.8	9.4
2	1750	A8/X	1315-0	50	1.44	5.7	17.1
1 1/2	1140	A8/X	860-0	40	1.12	6.7	17.1
3	1750	A10/X	1340-0	50	2.06	8.0	53.5
2	1140	A10/X	875-0	40	1.30	7.7	53.5
5	1750	A12/X	1340-0	50	3.44	13.3	53.5
3	1140	A12/X	875-0	40	2.10	12.4	53.5

HSV-A/Y UNIT (Internal Gear Increase)

INPUT		Model	OUTPUT				
HP	RPM		RPM Range	Stable RPM	HP@ Max.	Running TQ (ft.lb.)	Start TQ (ft.lb.)
1/2	1750	A2/Y	2735-0	50	0.35	0.7	4.8
1/3	1140	A2/Y	1780-0	40	0.25	0.7	4.8
1	1750	A4/Y	2615-0	50	0.72	1.4	9.2
3/4	1140	A4/Y	1705-0	40	0.56	1.7	9.2
2	1750	A8/Y	2330-0	50	1.44	3.2	16.9
1 1/2	1140	A8/Y	1520-0	40	1.12	3.8	16.9
3	1750	A10/Y	2290-0	50	2.06	4.7	25.8
2	1140	A10/Y	1490-0	40	1.30	4.5	25.8
5	1750	A12N	2290-0	50	3.44	7.8	25.8
3	1140	A12N	1490-0	40	2.10	7.3	25.8

Dimensions - HSV Hydrostatic Speed Variators

Type 10 Standard Units

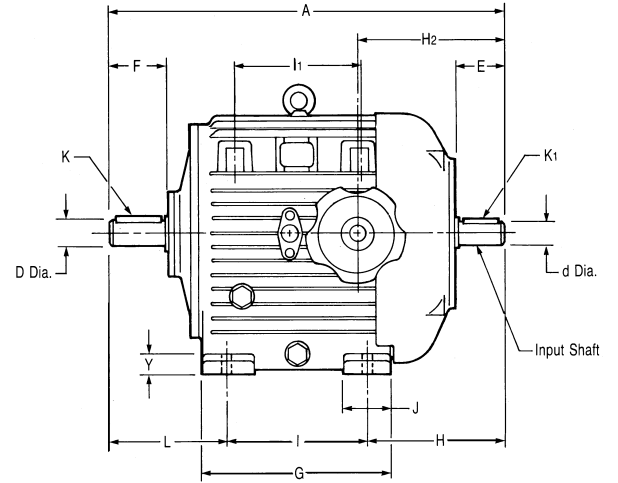
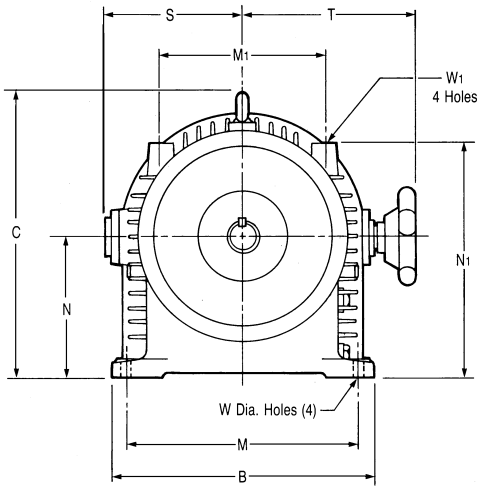

Type 11 NEMA C-flange Input and Output

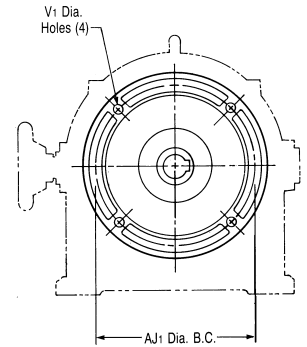
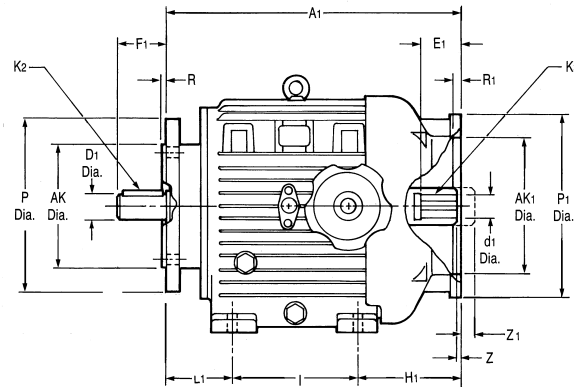
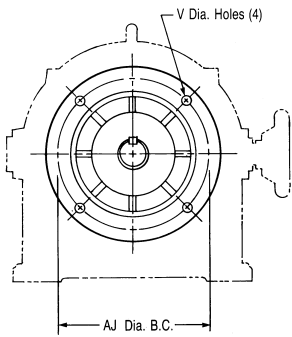

NEMA Frame Size/ Unit Weights

HSV Size	Input	Output	Wt. (lbs.)
11	56C	56C	23
12	143TC	143TC	29
13	145TC	145TC	60
14	182TC	182TC	71
15	184TC	184TC	132
16	215TC	215TC	288
16B	—	215TC	330
17	—	284TC	484
17B	—	284TC	540

Type 21 Motor Variator with NEMA C-flange motor on input

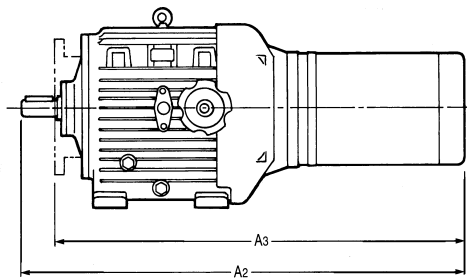

Type 22 Motor Variator with top- mounted motor

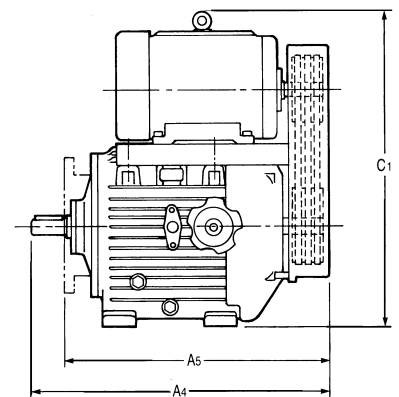

Dimensions - HSV Hydrostatic Speed Variators

HSV Size	A	A ₁	B	C	d	d ₁	D	D ₁	E	E ₁	F	F ₁	G	H	H ₁	H ₂	I	I ₁	J	K	K ₁	K ₂
11	10.03	8.46	7.09	7.24	.625	.625	.875	.625	1.188	2.99	1.750	1.75	4.37	3.16	3.09	3.0	3.15	3.54	1.18	.188	.188	.188
12	12.70	9.87	7.87	7.95	.875	.875	.875	.875	1.625	3.17	2.250	2.12	5.31	4.07	3.31	4.2	3.94	3.54	1.38	.188	.188	.188
13	15.03	11.07	10.63	10.16	.875	.875	.875	.875	2.000	3.05	2.250	2.12	6.81	4.97	3.33	5.0	4.84	4.65	1.97	.188	.188	.188
14	16.49	12.20	11.18	10.94	1.125	1.125	1.125	1.125	2.000	3.36	2.750	2.88	7.09	5.31	3.84	5.4	5.12	4.92	1.97	.250	.250	.250
15	20.64	17.22	13.54	14.53	1.375	1.125	1.375	1.125	2.375	2.95	3.375	2.88	9.45	7.06	6.93	7.7	7.09	6.30	2.36	.312	.312	.250
16	26.85	23.14	16.54	16.93	1.625	1.375	1.625	1.375	3.125	4.25	4.000	3.38	12.20	9.01	8.96	9.5	9.25	7.87	2.95	.375	.375	.312
16B	33.82	—	16.54	17.72	1.625	—	1.625	1.375	4.250	—	4.000	3.38	12.20	15.98	—	16.5	9.25	7.87	2.95	.375	.375	.312
17	31.23	—	19.69	21.10	1.875	—	1.875	1.875	4.250	—	4.525	4.62	15.16	10.31	—	11.31	11.61	9.72	3.54	.500	.500	.500
17B	37.36	—	19.69	21.10	1.875	—	1.875	1.875	4.250	—	4.525	4.62	15.16	16.44	—	17.2	11.61	9.72	3.54	.500	.500	.500

HSV Size	K ₃	L	L ₁	M	M ₁	N	N ₁	P	P ₁	R	R ₁	S	T	V	V ₁	W	W ₁	Y	Z	Z ₁	AJ	AJ ₁	AK	AK ₁
11	.188	3.72	2.22	6.10	4.41	3.74	6.30	6.50	6.50	.156	.188	3.94	5.43	.41	.41	.35	M6	.59	.188	—	5.88	5.88	4.50	4.50
12	.188	4.69	2.56	6.50	4.13	4.33	7.32	6.50	6.50	.156	.188	4.25	6.02	.41	.41	.35	M8	.59	—	.219	5.88	5.88	4.50	4.50
13	.188	5.22	2.90	9.06	5.51	5.51	9.57	6.50	6.50	.156	.188	5.31	7.40	.41	.41	.47	M8	.91	—	.188	5.88	5.88	4.50	4.50
14	.250	6.06	3.24	9.25	6.30	5.91	10.31	9.00	9.00	.250	.219	5.71	7.80	.52	.52	.47	M10	.91	.094	—	7.25	7.25	8.50	8.50
15	.250	6.49	3.70	12.01	8.27	7.09	11.81	9.00	9.00	.250	.219	6.69	8.86	.52	.52	.47	M10	.91	.219	—	7.25	7.25	8.50	8.50
16	.312	8.59	4.93	14.17	9.45	8.66	14.37	10.00	10.00	.250	.219	7.60	10.31	.52	.52	.57	M12	1.34	.219	—	7.25	7.25	8.50	8.50
16B	—	8.59	4.93	14.17	9.45	8.66	14.37	10.00	—	.250	—	9.06	10.31	.52	—	.57	M12	1.34	—	—	7.25	—	8.50	—
17	—	9.31	5.08	16.93	11.42	11.02	17.72	11.25	—	.250	—	8.94	11.50	.52	—	.71	M14	1.57	—	—	9.00	—	10.50	—
17B	—	9.31	5.08	16.93	11.42	11.02	17.72	11.25	—	2.50	—	9.06	11.50	.52	—	.71	M14	1.57	—	—	9.00	—	10.50	—

Note: Metric input and output shafts and IEC standard flanges are available upon request.

Type 21 and 22 Dimensions (in)

HSV Size	A ²	A ³	A ₄	A ₅	C ₁
11	19.27	17.52	10.49	8.74	13.18
12	23.19	21.07	12.96	10.84	14.70
13	24.64	22.52	15.51	13.39	17.45
14	27.58	24.70	16.46	13.58	19.25
15	34.45	31.57	21.34	18.46	23.25
16	CF	38.20	27.70	24.32	25.61
16B	—	—	35.10	31.72	33.96
17	—	—	32.10	27.48	36.24
17B	—	—	38.64	34.02	36.47

Type 30

Variator-reducer combination

Type 31

Variator-reducer with C-flange input kit

Type 32

Variator-reducer with top-mount kit

Type 41

Motor-Variator-Reducer combination with C-flange motor and reducer (In-line configuration)

Type 42

Motor-Variator-Reducer combination with top-mounted motor

The dimensions for Type Nos. 30 to 42 can be found by adding the dimensions of the types 10, 11, 21 and 22 to the gear reducer dimensions shown on page E1—9.

Dimensions - HSV-A (IN.)

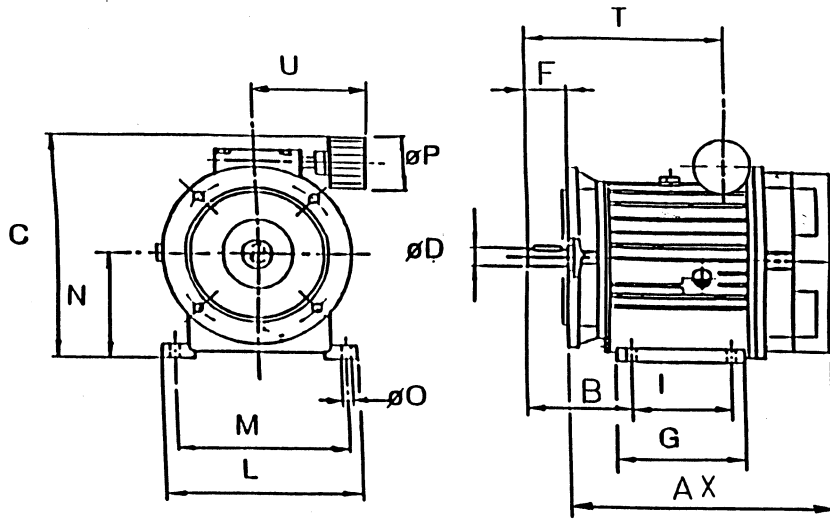

TYPE 11
(C in – C out)
(Std. configuration)

HSV Model	B	C	D	F	G	I	L	M	N	O	P	T	U	AX	NEMA Frame	Weight lbs.
A2	3.48	7.4	0.625	1.75	3.74	2.68	6.89	5.7	3.27	0.35	1.97	6.24	4.76	7.4	56	20
A4	4.09	8.54	0.875	2.12	4.33	3.15	7.83	6.69	4.02	0.35	1.97	7.12	4.76	8.13	140	27
A8	4.68	9.21	0.875	2.12	5.12	3.54	9.33	8.19	4.13	0.47	1.97	8.14	4.76	12.44	140	45
A10	5.88	11.08	1.125	2.875	5.71	3.94	10.63	9.45	5.12	0.47	1.97	9.67	4.76	13.3	180	75
A12	5.88	11.08	1.125	2.875	5.71	3.94	10.63	9.45	5.12	0.47	1.97	9.67	4.76	13.3	180	75

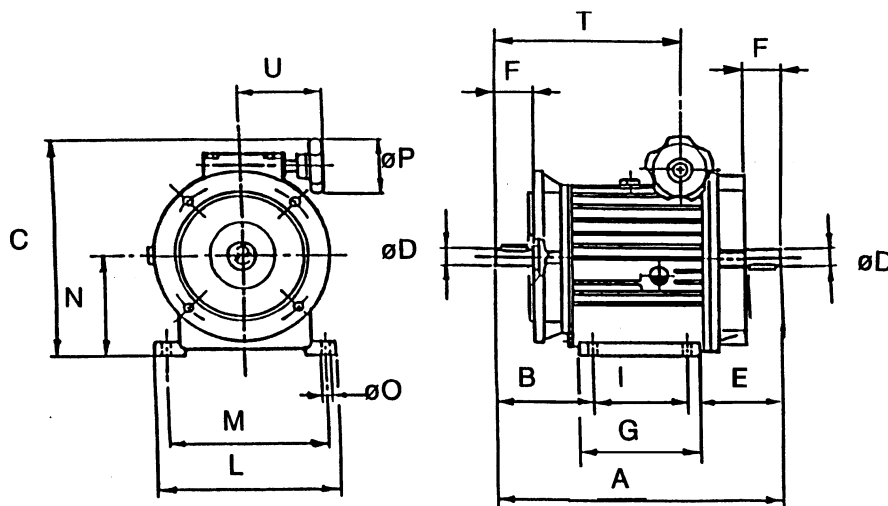

TYPE 10
(Shaft in – Shaft out)

HSV Model	A	B	C	D	F	G	I	L	M	N	O	P	T	U	E
A2	9.95	3.48	7.40	.625	1.75	3.74	2.68	6.89	5.71	3.27	0.35	1.57	8.24	4.76	3.79
A4	11.5	4.09	8.54	.875	2.12	4.33	3.15	7.83	6.69	4.02	0.35	1.57	7.12	4.76	4.26
A8	12.99	4.68	9.21	.875	2.12	5.12	3.54	9.33	8.19	4.13	0.47	1.57	8.14	4.76	4.77
A10	19.32	5.88	11.08	1.125	2.875	5.71	3.94	10.63	9.45	5.12	0.47	1.97	9.67	4.76	9.5
A12	19.32	5.88	11.08	1.125	2.875	5.71	3.94	10.63	9.45	5.12	0.47	1.97	9.67	4.76	9.5

Dimensions - Gear Reducers

Single Reduction

DC11, 21, 31, 41, 51

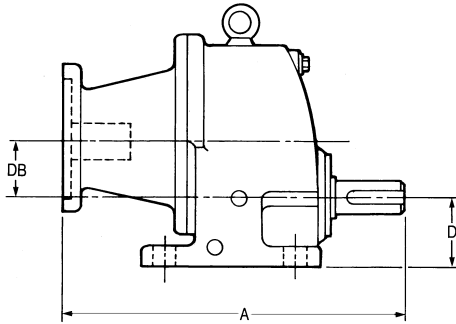

Double Reduction

DC02, 12, 22, 32, 42, 52, 62, 72, 82, 92

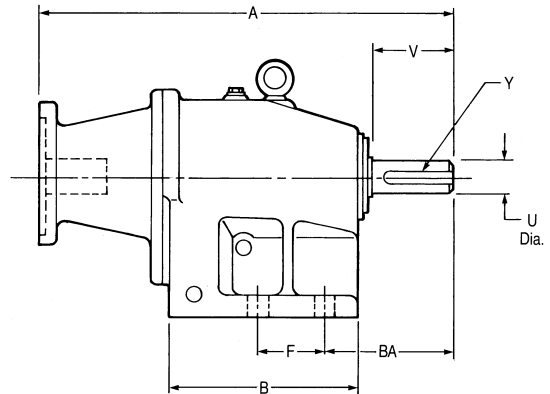

Triple Reduction

DC23, 33, 43, 53, 63, 73, 83, 93, 103

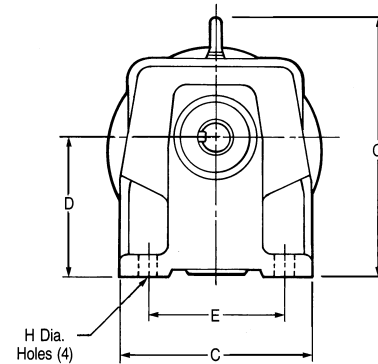
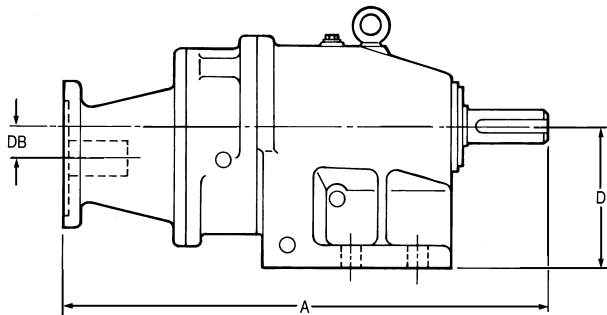

Reducers

Dimensions (inches)

Gearbox Size	A*	NEMA Frame Size	B	BA	C	D	DB	E	F	H	O	U	V	Y
DC 02	11.5	—	5.28	1.97	5.12	3.39	—	4.33	2.36	0.35	6.7	0.750	1.50	0.188
DC 11	9.3	—	3.94	2.12	5.31	2.20	1.97	4.13	3.15	0.35	7.4	0.750	1.50	0.188
DC 12	12.7	—	5.47	3.22	5.31	4.02	—	4.13	2.44	0.35	7.3	1.000	2.13	0.250
DC 21	10.8 12.8	56C/145TC 182TC/184TC	5.51	2.75	7.28	2.80	2.40	6.30	4.53	0.43	9.7	1.000	2.13	0.250
DC 22	14.4 15.3	56C/145TC 182TC/184TC	6.89	3.30	7.28	4.92	—	6.30	3.15	0.43	8.8	1.250	2.75	0.250
DC 31	14.3 16.5	182TC/215TC 56C/145TC	6.50	3.50	8.27	3.35	2.99	6.89	5.31	0.51	12.13	1.250	2.75	0.250
DC 32	18.5* 13.1	182TC/215TC 56C/145TC	8.43	3.88	8.27	6.10	—	6.89	4.72	0.51	11.50	1.625	3.25	0.375
DC 41	16.7 18.1	182TC/215TC 56TC/145TC	8.07	3.94	8.46	3.94	3.39	6.89	6.50	0.51	14.33	1.375	3.00	0.313
DC 42	21.7*	182TC/215TC	9.41	5.07	8.46	6.89	—	6.89	4.72	0.51	12.87	1.875	3.50	0.500
DC 51	17.3	—	8.66	4.19	10.24	4.41	4.17	8.46	7.09	0.71	15.94	1.625	3.25	0.375
DC 52	23.7*	—	11.14	5.18	10.24	8.35	—	8.66	5.91	0.71	15.08	2.250	4.00	0.500
DC 62	26.6 28.7	182TC/215TC 284TC/286TC	13.58	6.34	12.99	9.84	—	10.24	11.61	0.87	18.91	2.500	5.00	0.625
DC 72	28.1 30.3	182TC/215TC 284TC/286TC	15.16	7.04	15.75	11.02	—	12.80	12.90	1.02	21.65	3.000	5.50	0.750

* Overall length on 182TC/184TC flange size may be shorter.

HSV-A

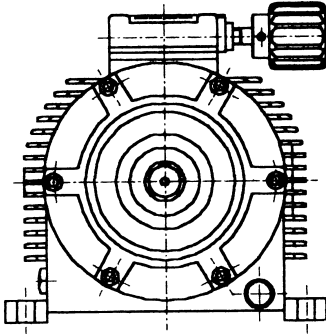

Code 00

Standard Handwheel Control

This is the standard control supplied with the HSV. It provides precise speed control in both directions and ease of operation. The number of turns from maximum reverse to forward and the operating torque is shown in the table below.

HSV

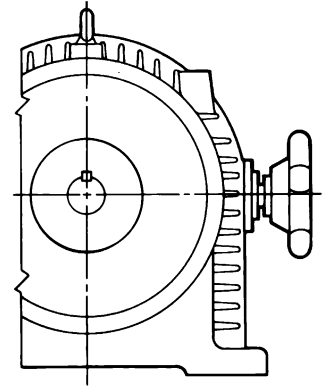

Code 01

Right Angle Handwheel Control

This control incorporates a bevel gear set and operates identically to the Code 00. The handwheel can be rotated to several positions so that it faces down, horizontal or some other convenient angle.

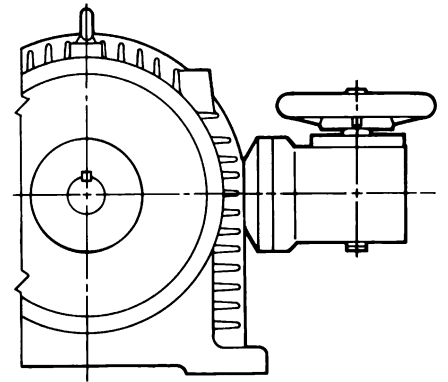
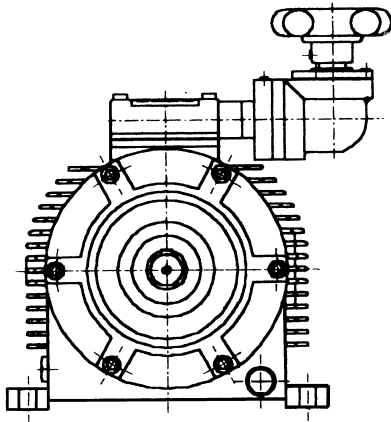

Code 02

Lever Control

This lever control operates over approximately 90 degrees from maximum reverse to forward. It has a friction clutch to adjust the amount of force required to stroke it and will stay in place when set. The control can be adjusted to locate this zero position at different angular locations. There is about 5 degrees of deadband in the control on either side of the center zero position.

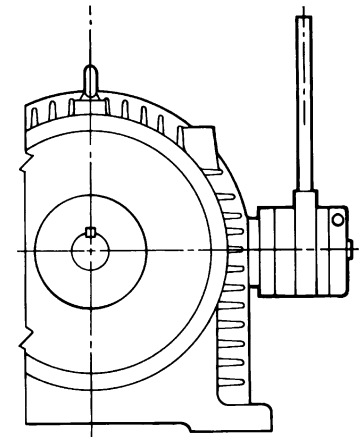
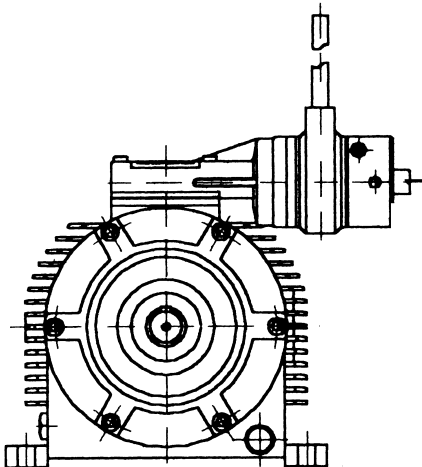

HSV-A

NOT AVAILABLE

**Code 03
Heavy Duty Lever Control**

This operates in the same manner as the Code 02 but is recommended for more frequent use. It is also available in a flanged version (Code 03F) to mount some other device such as a chain sprocket for example.

HSV

NOT PICTURED

NOT AVAILABLE

**Code 09
Handwheel Control
with Flexible Shaft**

This control incorporates 6 feet of flexible shaft for remote mounting the handwheel to a bracket or panel. Available on sizes 11 through 15 only.

NOT PICTURED

NOT AVAILABLE

**Code 12
Clevis Control**

This high force control is directly connected to the variator pump eccentric ring. Stroking the clevis in and out changes the speed. The Zeroing Device (option 6) can be added to assure a return to zero speed when control forces are released. Force requirements and maximum clevis travel are shown in the table below.

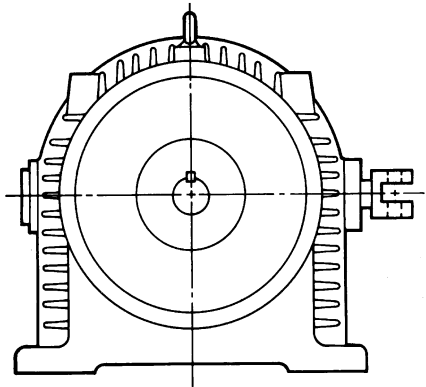

Electronic Remote Controls (ERC)

HSV-A

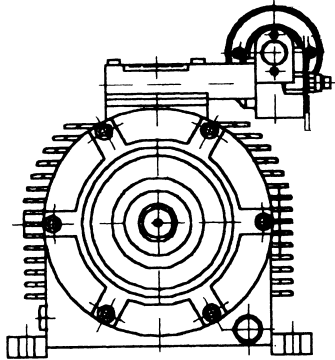

Code 20 ERC (Fast)

The ERC's consist of a small motor driving a worm gear through a slip clutch to control the position of the eccentric ring in the variator. The slip clutch allows for a manual hand-wheel override and protects the small electric motor from stalling if over-controlled. The response time from zero to maximum speed is 14 seconds. The standard motor is a permanent split capacitor type. The position of the motor can be rotated around the axis of the handwheel. See notes below.

HSV

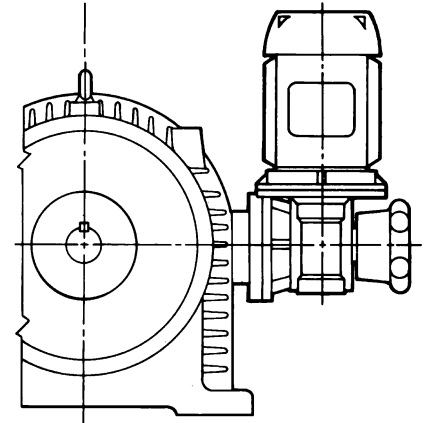

Code 22 ERC (Slower)

This control operates more slowly than the Code 20 requiring 50 sec. to go from zero to maximum speed. All other features are the same.

Notes:

1. Pushbuttons are not supplied with the control.
2. Pushbuttons should be crosswired to protect the motor.
3. Control motors with other voltages and enclosures are available at additional cost.

Code 22 ERC (Slower)

This control operates more slowly than the Code 20 requiring 50 sec. to go from zero to maximum speed. All other features are the same.

Code 23 ERC (Slowest)

This control operates more slowly than the Code 20 requiring 125 sec. to go from zero to maximum speed. All other features are the same.

Code 23 ERC (Slowest)

This control operates more slowly than the Code 20 requiring 125 sec. to go from zero to maximum speed. All other features are the same.

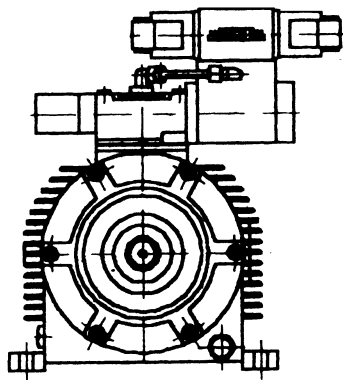

Code 31 PLC / Hydraulic

This control interfaces with a digital electronics card on the customers machine (PLC or PC). This control provides for infinite speed control and bi-directional operation with feed back. The solenoid valve may also be pulsed to provide proportional speed control.

NOT AVAILABLE

HSV-A

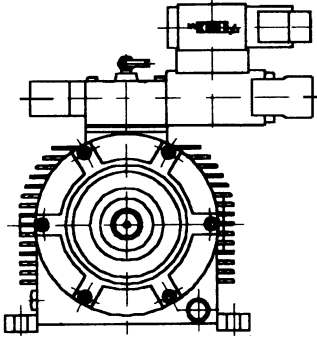

Code 37

Electronic Control

This Electro-Hydraulic - Electronic proportional control provides a continuous speed adjustment by means of closed loop regulation. It will ensure speed stability even when there is a large variation in load. The control accepts a continuously changing reference signal and can provide adjustable acceleration and deceleration ramps. Speed regulation can be obtained using potentiometers or analog signals. The control uses an Electronic card with speed feedback sensor and proportional solenoid valve. Direction of rotation must be specified.

HSV

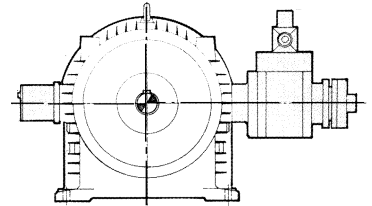

Code 38

Electronic Control

Same as Code 37 but includes a second solenoid valve to allow for mechanical zeroing of input shaft

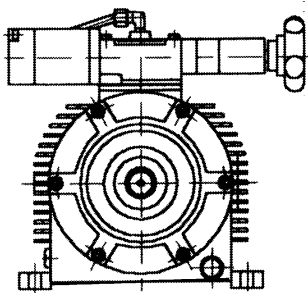

Code 46

Gradual Start Manual

This control provides handwheel control but includes adjustable start times from 2 to 20 seconds. It is recommended for high inertia starting. Direction of rotation must be specified. For bi-directional operation, a Code D reversible charge pump is required.

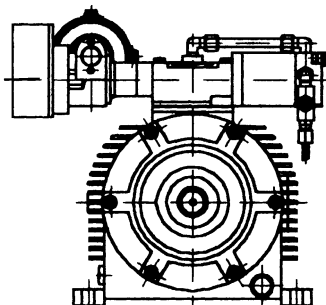
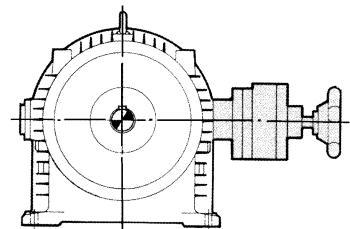

Code 49

Gradual Start ERC

Same as Code 46 except uses an electric gear motor control rather than the handwheel.

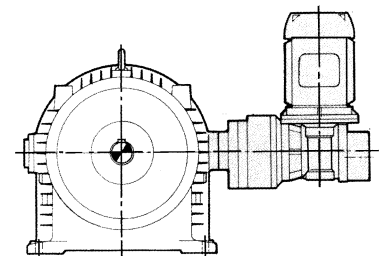

Pneumatic Proportional Controls

HSV-A

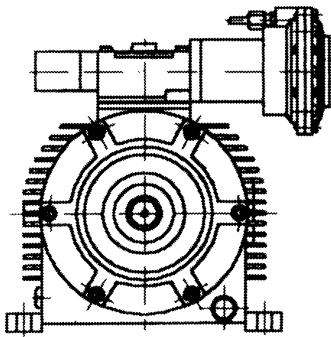

NOT AVAILABLE

Code 52

Hydropneumatic Proportional Control (3-15 psi)

Instrument air pressure at 3-15 psi is used to stroke this control from zero to the maximum speed. For CW rotation the control is mounted on the left; for CCW rotation the control is mounted on the right. Ideal for explosion-proof environments this control is sensitive, rugged and reliable. Simple in design, it has only one diaphragm and two springs.

Note: Control for one direction only. Specify rotation direction.

Code 53

Hydropneumatic Proportional Control (15-45 psi)

This control is identical in construction to the Code 52 except it has a smaller diaphragm to accept higher air pressures. In addition, it has a small needle valve in the hydraulic supply line to meter oil into the control thereby providing an adjustable acceleration time (ramping). Rotation and mounting considerations are the same as the Code 52.

Note: Control for one direction only. Specify rotation direction.

HSV

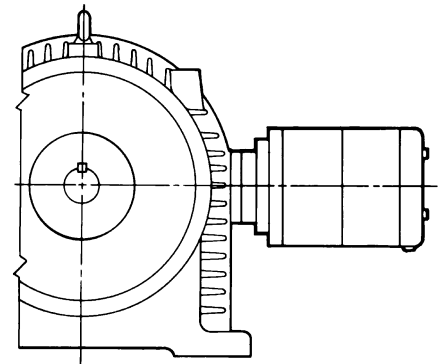
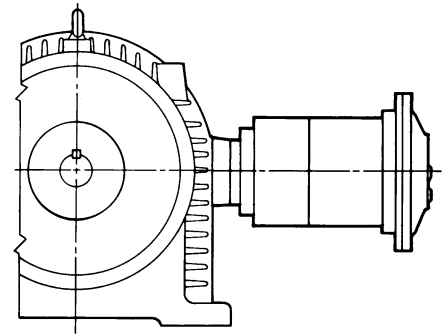

Electrohydraulic Remote Controls

All of the electrohydraulic controls consist of a double-acting cylinder controlled by a 4-way valve. Powered by the charge pump, the controls are fully reversible. Manually preset speeds and liner (jerk-free) accelerations are the important features of these controls.

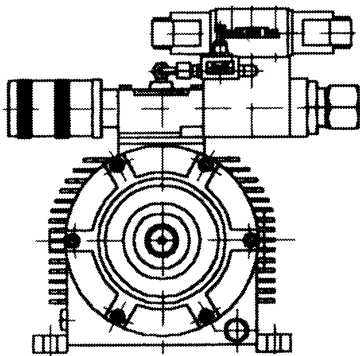

Code 65

Electrohydraulic Control with two preset speeds and zeroing device

This allows the HSV to operate at two different speeds which are preset by ring nuts. A small flow control valve permits controlled acceleration between the two speeds. Releasing both solenoids on the directional valve brings the control to zero speed without shutting off the input motor.

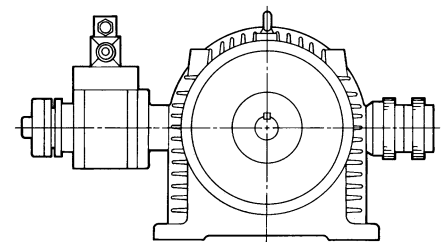

HSV-A

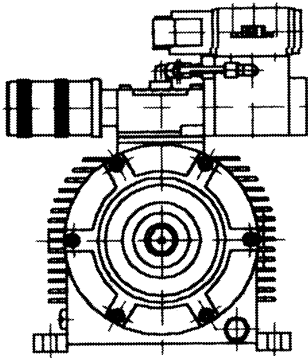

NOT AVAILABLE

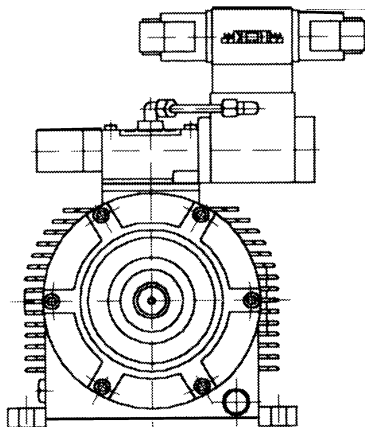

NOT AVAILABLE

Code 66

Electrohydraulic Control with two preset speeds only

Identical in function to the Code 65, this control operates only at one or the other of two preset speeds. Zeroing of the control is assured only if one of the ring nuts is set at zero speed.

Code 67

Electrohydraulic remote control with zeroing device

This control incorporates a cylinder locking valve and two flow controls that meter oil out of the control. This allows the control to lock into any speed while accelerating or decelerating (linear ramping). Furthermore, the two flow controls allow independent control of acceleration and deceleration ramps. When the HSV is shut off the control automatically moves to the zero speed position.

Code 67

Remote Electrohydraulic Control

This control adjust the variator speed through push buttons and gives the same control as code 20 (Remote Electric Control). This control is recommended when rapid acceleration and deceleration is required or when there are frequent speed changes. The control also contains a device to adjust the acceleration and deceleration ramp.

Code 68

Electrohydraulic remote control with electrical auxiliary zeroing device

A solenoid valve (19A) is used to cut flow to the control thereby allowing it to stroke to zero speed without having to shut off the driving motor. In all other aspects the control is identical to the Code 67. Solenoid 19A must be energized for the control to operate. The auxiliary zeroing feature is not intended to be used as an emergency shutdown, it merely overrides any preset ramps.

HSV

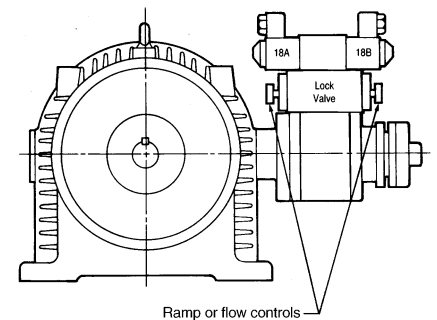
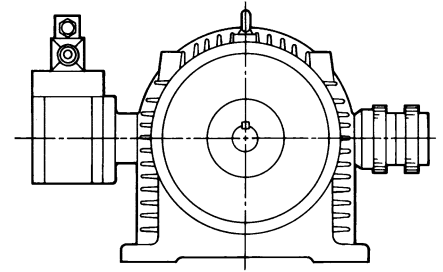

NOT AVAILABLE

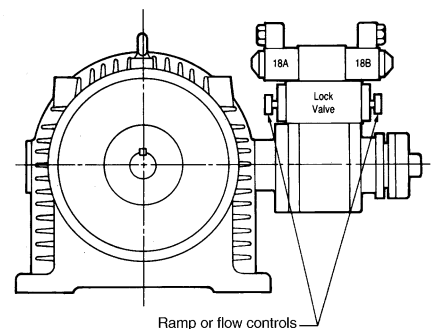

HSV-A

HSV

Code 71

Synchronized Control

The control synchronizes two speeds (primary and secondary). Power factor correction is substituted by this control. The Synchronizer Control is mainly used on Packaging Machines (Flow Pack Systems).

NOT AVAILABLE

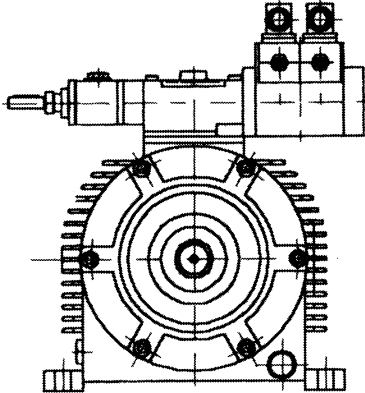

The control is used to keep the label and bags in a central position compared to the bag length. The control has two input controls: one by handwheel setting the feed or the package length, the second utilizes a piloted impulse to a solenoid valve from proximity switches or from a photo-electric cell. This latter signal allows the handwheel setting to be increased or decreased to ensure the label position central on the bag.

Code 0013

Device For Automatic Winders

It permits controlling output shaft variable speed of the variator according to the resistance torque. Speed is automatically decreased according to the increasing diameter of the reel and corresponding peripheral speed. This permits winding at a controlled tension with a 1:6 ratio of minimum and maximum diameter. In order to get lower or higher tension values, it is necessary to make manual regulations with handwheel.

NOT AVAILABLE

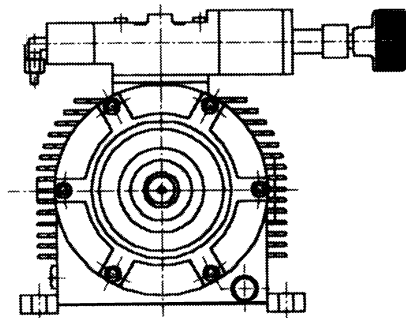

When placing orders please state direction of rotation of output shaft.

The Hydrostatic Speed Variator is available with a wide variety of accessories and options that can extend and improve the capabilities of the standard control mechanisms as well as monitor and control system loading.

HSV-A

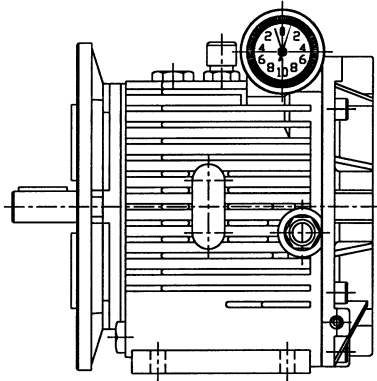

Code 0

Handwheel with Indicator Dial HSV & HSV-A

The gravity type indicator has a scale which reads the number of hand-wheel turns and fractions thereof. It allows an operator to set the speed and then return to it when needed. It does not provide a direct speed read-out. The hands on the dial operate like the hands of a clock.

HSV



Code 3

Device for Automatic Winders (Pressure Compensator) HSV Only

This device monitors torque load on the HSV by sensing system pressure. It destrokes or slows down the unit in response to increasing torque thereby eliminating the need for a dancing roller on a windup machine. Other applications involving load sensing are possible. Contact the factory for further details.

Code 4

Adjustable Torque-Limiting (Relief) Valves HSV Only

This inexpensive device can decrease the relief valve setting to limit torque in torque-sensitive applications. Starting torque capability is likewise reduced.

Code 6

Zeroing Device HSV Only

This device will spring center the eccentric ring of the HSV to bring the drive to zero speed. It can be used in conjunction with control codes 02,03 and 12 for a positive control to zero.

Code 8

Tachometer Package HSV & HSV-A

A two-pole pickup in the HSV generates a small alternating current whose voltage is proportional to the RPM. The pickup and wheel are contained inside the HSV. The position of the pickup can be rotated. The meter can be calibrated to almost any scale, for example feet per minute or gallons per minute, etc. A digital tachometer is available at additional cost.

Code 9

Limit Switch Boxes for Presetting Speeds HSV & HSV-A

The switch boxes mount on the HSV opposite the control mechanism and are used to set speeds in conjunction with control codes 20, 22, 67 and 68.

Code 9 (2) Sets 2 speeds

Code 9 (3) Sets 3 speeds

Code 9 (6) Sets 4 speeds and zero speed

Options

Code A – HSV only **Separate Charge Pump**

This option gives design flexibility in two areas. First it allows the HSV to accept input speeds below 900 RPM. Secondly, it allows for reversal of the input shaft rotation to get bi-directional performance out of uni-directional controls (Codes 52 and 53). The external pump is also supplied with small driving motor.

Code B – HSV only **Bypass Valve**

The bypass valve is connected to both sides of the hydrostatic closed loop. When open it allows flow from one side to the other bypassing the hydraulic motor. It is intended for applications requiring the HSV output shaft to freewheel when shut off. It can also be used when a brake is applied to the output shaft. Pressure drop through the valve when the HSV is stroked and running will result in rotation of the output shaft.

Code C – HSV & HSV-A **Vertical Mount Kit**

The HSV can be mounted with shafts vertical or with feet on a side-wall. To do so requires the installation of a vertical mount kit which is a small duct to supply the charge pump inlet with oil. Not available on the model 16B or 17B.

Code D – HSV & HSV-A **Reversible Charge Pump for HSV Sizes 11, 12, 13, 14, 15, A2, A4, A8, A10, A12**

This option allows for reversal of the input electric motor, thereby gaining two advantages: Bi-directional performance from uni-directional controls codes (52 and 53), and doubling the number of preset speeds for the controls and options that offer them.

Code F – HSV only **Flow Controls for codes 65 and 66**

These allow independent acceleration and deceleration ramps to be set for the two controls.

Code G – HSV & HSV-A **Potentiometer Feedback**

It is a device supplied on request with control code 20-22-23. The code G is a linear potentiometer that reads the exact relationship of the position of the variator control to the speed of the variator. Any speed change causes a movement of the potentiometer and hence a change of signal. The potentiometer gives a feedback to the electronic card (RCF) or other device allowing a continuous control of the unit speed.

Code M – HSV & HSV-A **Pressure Tap**

System pressure which is proportional to torque can be monitored with the pressure tap. A gauge can be used to monitor torque or a pressure switch can be tripped to limit torque and protect the system. A single tap to read one side of the hydrostatic loop or a double tap to read both sides is available. A pressure gauge or a pressure activated switch is available.

Code N – HSV & HSV-A **Thermo Switch**

This option provides a switch if the HSV unit exceeds a predetermined temperature.

Code P – HSV & HSV-A **Preheat Kit**

This consists of 1 or 2 immersion heaters and a thermostwitch to pre-heat the oil for extremely cold environments. They are rated for 115 VAC, 60 Hz.

Code Q – HSV only **Compensated Flow Control**

This pressure and temperature compensated flow control provides more uniformity of control response under varying temperature conditions. It can be incorporated into any hydraulic control powered by the charge pump.

Code R – HSV & HSV-A **Oil Cooler Package**

This option consists of a cooler valve and a radiator with fan motor to cool the oil in high ambient temperature applications. Excess charge pump flow is brought outside the HSV with the cooler valve. It is then sent to the air-oil heat exchanger and returned to the case of the drive. Other types of heat exchangers may be used in conjunction with the valve.

Code S – HSV & HSV-A **Electronic Adjuster**

This device is exclusively coupled with electric controls (code 20-22-23-31 and 67).

The card allows the proportional adjustment of the control dependent upon the input preset signal. The RCF adjuster operated in a closed loop using a voltage signal from a potentiometer (code G) which continually monitors the situation of the variator (for controls 20-22-23). The RCF-FT adjuster can have a feedback also from Code 8 (directly speed feedback).

Code W – HSV only **Remote Speedset Device**

Used in conjunction with control Codes 65 and 66, this electrohydraulic device can be remotely set to two equal speeds in opposite directions of rotation.

Code Z – HSV & HSV-A **Miscellaneous Options**

- Epoxy Paint
- Synthetic Oil
- Stainless Steel Shafts and Hardware
- Special Breather

The breather option is recommended for dusty, dirty and heavy washdown environments. A pressure activated, sintered metal breather, excludes contaminants for the interior of the HSV case.

Note: Accessory Codes 3 and 4 and Option Codes B and M are mutually exclusive. Only one may be mounted to a variator.

The Power Of One, The Strength Of Many.

OTHER PRODUCT SOLUTIONS FROM
ALTRA INDUSTRIAL MOTION

WWW.ALTRAMOTION.COM

Our comprehensive product offerings include various types of clutches and brakes, overrunning clutches, engineered bearing assemblies, gearing and gear motors along with linear products, belted drives, couplings and limit switches. With thousands of product solutions available, Altra provides true single source convenience while meeting specific customer requirements. Many major OEMs and end users prefer Altra products as their No. 1 choice for performance and reliability.



ELECTRIC CLUTCHES AND BRAKES

Inertia Dynamics
Matrix
Stromag
Warner Electric



HEAVY DUTY CLUTCHES AND BRAKES

Industrial Clutch
Stromag
Svendsborg Brakes
Twiflex
Wichita Clutch



OVERRUNNING CLUTCHES

Formsprag Clutch
Marland Clutch
Stieber



ENGINEERED COUPLINGS AND UNIVERSAL JOINTS

Ameridrives
Bibby Turboflex
Guardian Couplings
Huco
Lamiflex Couplings
Stromag
TB Wood's



GEAR DRIVES

Bauer Gear Motor
Boston Gear
Delroyd Worm Gear
Nuttall Gear



GEAR MOTORS

Bauer Gear Motor



POWER TRANSMISSION COMPONENTS

LINEAR ACTUATORS AND CONTROLS

Warner Linear



ENGINEERED BEARING ASSEMBLIES

Kilian



AIR MOTORS

Huco



BELTED DRIVES AND SHEAVES

TB Wood's



GEARED CAM LIMIT SWITCHES

Stromag

Altra Industrial Motion

TB Wood's Facilities

North America

USA

440 North Fifth Avenue
Chambersburg, PA 17201 - USA
888-829-6637 * 717-264-7161
Belted Drives and Elastomeric Couplings

Customer Service

1-888-829-6637 (Press #5)

For Application Support

1-888-829-6637 (Press #7)

2000 Clovis Barker Road
San Marcos, TX 78666 - USA
1-888-449-9439
General Purpose Disc Couplings

Customer Service

1-888-449-9439

4970 Joule St
Reno, NV 89502 - USA
775-857-1800

Canada

9779 45 Ave NW
Edmonton, AB T6E 5V8 - Canada
+1 780-439-7979

6305 Danville Road
Mississauga, ON L5T 2H7 - Canada
1-800-829-6631

1073 Rue Bégin
Saint-Laurent, QC H4R 1V8 - Canada
+1 514-332-4812

Mexico

Comisión Federal de Electricidad 850,
Industrial San Luis,
San Luis, S.L.P., 78395 - Mexico
+52 444 137 1500

Europe

Merchant Drive, Hertford
Hertfordshire SG13 7BL - England
+44(0)1992 501900
Elastomeric Couplings

The Brands of Altra Industrial Motion

Couplings

Ameridrives
www.ameridrives.com

Bibby Turbobox
www.bibbyturbobox.com

Guardian Couplings
www.guardiancouplings.com

Huco
www.huco.com

Lamiflex Couplings
www.lamiflexcouplings.com

Stromag
www.stromag.com

TB Wood's
www.tbwoods.com

Gear Cam Limit Switches

Stromag
www.stromag.com

Electric Clutches & Brakes

Inertia Dynamics
www.idicb.com

Matrix
www.matrix-international.com

Stromag
www.stromag.com

Warner Electric
www.warnerelectric.com

Linear Products

Warner Linear
www.warnerlinear.com

Engineered Bearing Assemblies

Kilian
www.kilianbearings.com

Heavy Duty Clutches & Brakes

Industrial Clutch
www.indclutch.com

Twiflex
www.twiflex.com

Stromag
www.stromag.com

Svendborg Brakes
www.svendborg-brakes.com

Wichita Clutch
www.wichitaclutch.com

Belted Drives

TB Wood's
www.tbwoods.com

Gearing

Bauer Gear Motor
www.bauergears.com

Boston Gear
www.bostongear.com

Delroyd Worm Gear
www.delroyd.com

Nuttall Gear
www.nuttallgear.com

Overrunning Clutches

Formsprag Clutch
www.formsprag.com

Marland Clutch
www.marland.com

Stieber
www.stieberclutch.com

Neither the accuracy nor completeness of the information contained in this publication is guaranteed by the company and may be subject to change in its sole discretion. The operating and performance characteristics of these products may vary depending on the application, installation, operating conditions and environmental factors. The company's terms and conditions of sale can be viewed at <http://www.altramotion.com/terms-and-conditions/sales-terms-and-conditions>. These terms and conditions apply to any person who may buy, acquire or use a product referred to herein, including any person who buys from a licensed distributor of these branded products.

©2018 by TB Wood's LLC. All rights reserved. All trademarks in this publication are the sole and exclusive property of TB Wood's LLC or one of its affiliated companies.